



INTERNATIONAL APPLICATION PUBLISHED UNDER THE PATENT COOPERATION TREATY (PCT)

<p>(51) International Patent Classification ⁵ : A61B 17/56</p>	<p>A1</p>	<p>(11) International Publication Number: WO 93/25157 (43) International Publication Date: 23 December 1993 (23.12.93)</p>
<p>(21) International Application Number: PCT/EP93/01540 (22) International Filing Date: 17 June 1993 (17.06.93) (30) Priority data: P 42 19 939.5 18 June 1992 (18.06.92) DE (71)(72) Applicant and Inventor: RADERMACHER, Klaus [DE/DE]; Ludwigsallee 21, D-5100 Aachen (DE). (72) Inventors; and (75) Inventors/Applicants (for US only) : RAU, Günter [DE/DE]; Fuchserde 50, D-5100 Aachen (DE). STAUDTE, Hans-Walter [DE/DE]; Neue Furth 28, D-5102 Würselen (DE). (74) Agents: HILLERINGMANN, Jochen et al.; Deichmannhaus am Hauptbahnhof, D-5000 Köln 1 (DE).</p>	<p>(81) Designated States: CA, DE, US, European patent (AT, BE, CH, DE, DK, ES, FR, GB, GR, IE, IT, LU, MC, NL, PT, SE). Published <i>With international search report. Before the expiration of the time limit for amending the claims and to be republished in the event of the receipt of amendments.</i></p>	

(54) Title: **TEMPLATE FOR TREATMENT TOOLS AND METHOD FOR THE TREATMENT OF OSSEOUS STRUCTURES**

(57) Abstract

Of an osseous structure to be treated, a reconstruction is produced. On the basis of the contact points of this reconstruction, abutment points are defined for a template for guidance, alignment and positioning of a treatment tool. The contact points are defined in such a manner that the template can be mounted on the osseous structure in form-closed manner in exactly one spatially uniquely defined position. On such a template, the treatment tool is fastened and guided in such a manner that the treatment of the osseous structure can be performed corresponding to the previous planning of the surgical intervention.

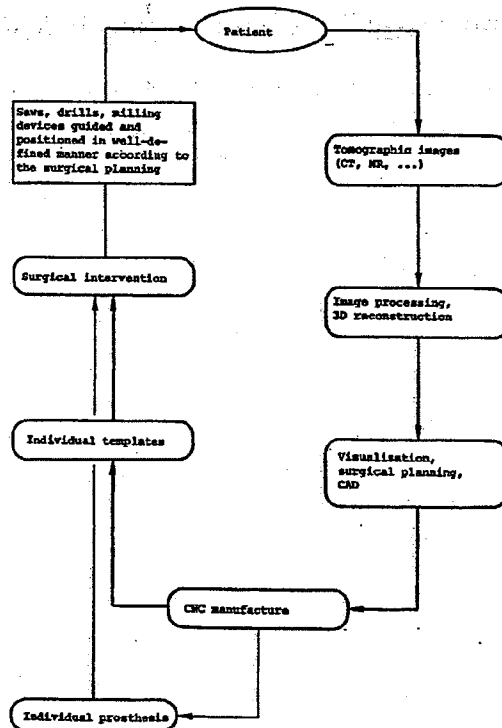

FOR THE PURPOSES OF INFORMATION ONLY

Codes used to identify States party to the PCT on the front pages of pamphlets publishing international applications under the PCT.

AT	Austria	FR	France	MR	Mauritania
AU	Australia	GA	Gabon	MW	Malawi
BB	Barbados	GB	United Kingdom	NL	Netherlands
BE	Belgium	GN	Guinea	NO	Norway
BF	Burkina Faso	GR	Greece	NZ	New Zealand
BG	Bulgaria	HU	Hungary	PL	Poland
BJ	Benin	IE	Ireland	PT	Portugal
BR	Brazil	IT	Italy	RO	Romania
CA	Canada	JP	Japan	RU	Russian Federation
CF	Central African Republic	KP	Democratic People's Republic of Korea	SD	Sudan
CG	Congo	KR	Republic of Korea	SE	Sweden
CH	Switzerland	KZ	Kazakhstan	SK	Slovak Republic
CI	Côte d'Ivoire	LJ	Liechtenstein	SN	Senegal
CM	Cameroon	LK	Sri Lanka	SU	Soviet Union
CS	Czechoslovakia	LJ	Luxembourg	TD	Chad
CZ	Czech Republic	MC	Mongo	TG	Togo
DE	Germany	MG	Madagascar	UA	Ukraine
DK	Denmark	ML	Mali	US	United States of America
ES	Spain	MN	Mongolia	VN	Viet Nam
FI	Finland				

Template for treatment tools and method for the
treatment of osseous structures

The invention is directed to a template for treatment tools for the treatment of osseous structures and a method for the definition and reproduction of the positional relationship of a treatment tool relative to an osseous structure.

Using image producing methods such as computertomography and computer-based image-processing systems, it is possible to record osseous structures of the living organism in slices by a non-invasive technique, to reconstruct them three-dimensionally and to visualize them through an output medium. Further, such systems frequently permit already a three-dimensional planning of surgical interventions with regard to incisions, drilling, puncture, positioning of individual implants or other surgical interventions. Intraoperatively, i.e. during the actual sur-

gical procedure, there often occur orientation problems because no adequate technical means exist for a consequent, exact three-dimensional transfer of the steps of the intervention which have been planned with a waste of technical support. Therefore, the accuracy of execution depends exclusively on the experience, the three-dimensional perceptivity and the technical skill of the surgeon, which, depending on the type and the anatomical site of the intervention can involve extreme risks even with experienced surgeons. Generally, only freehand-guided instruments, two-dimensional tomographic images and pre- or intraoperative X-ray images are available.

For some interventions, standard tool guides have been provided. These are mostly cutting, boring or sinking templates for preparing and/or fixing the seat of a knee or hip joint prosthesis (as e.g. US 4,567,885, US 4,703,751, US 4,822,362, US 4,721,104, DE-33 39 259, EP 380 451, EP 415 837, EP 231 885, EP 228 339, DE 39 25 488, DE 79 14 280) or for repositioning osteotomies in the region of the proximal head of the femur or tibia (e.g. US 4,565,191, DE 38 42 645, DE 32 11 153). The intraoperative positioning of these templates relative to the bone is performed free-handed and even in case of special solutions allowing limited adaptation to the anatomical conditions, as e.g. in US 4,846,161, DE 34 47 163 or DE 40 16 704, can generally not be carried out exactly and clearly according to the planning of the intervention. In some approaches, intraoperative measurement and positioning under X-ray control are provided. This causes an increased expo-

sure to radiation for the patient and the medical staff, prolongs the duration of the surgical intervention and again is just an indirect and not clearly defined transfer of the treatment strategy defined in the surgical planning.

There also exist devices for stereotactical interventions. Principally, these devices can be divided into two categories. The first category comprises devices which, designed as rigid frames, are attached directly (e.g. by screws) on/in the bone and are adapted for rigid mechanical coupling to a positioning or coordinate measuring system, with the reference points of said devices being reproduced in a tomographic image (e.g. stereotaxic apparatuses as described in Riechert et al.: Beschreibung und Anwendung eines Zielgerätes für stereotaktische Hirnoperationen, Acta neurochir., Vienna, Austria, Suppl. III (1955), 308; and in DE 37 17 871, DE 39 02 249 and EP 312 568). The second category comprises methods wherein individual reference bodies (marking elements, at least three of them) are fixed in or on the bone or the overlying skin surface already prior to tomographic scanning of the respective part of the body and subsequently are imaged in the tomographic pictures. These reference bodies and markers are then detected, as to their position and orientation, through a mechanically rigid construction or 3D coordinate measurement and evaluation for detection of the transformation relation between the coordinate systems of the bone structure, the tomographic images and the environment (Adams et al.: A navigation support for surgery. In: Höhne et al.:

3D-Imaging in Medicine. Nato ASI Series F.; Computer and System Science Vol. 60, Springer, 1990; Kosugi et al.: An articulated neurosurgical navigation system using MRI and CT images. IEEE Transactions on Biomedical Engineering, Vol. 35, No. 2, Feb.1988).

Since the relative position of the reference bodies or points relative to the osseous structures is known or can be obtained from the tomographic images, it is possible to use a 3D coordinate measuring or adjusting device, coupled to these reference bodies (or points) fixedly or through defined transformation relationships, for the positioning of coordinate measurement pins or guide devices for puncturing cannulae and drills.

Generally, these methods suffer from the following disadvantages:

- The reference bodies (markings, frames, other devices) can be fixed on the skin surface only in special cases (in the skull region or in the region of palpable sites on osseous structures), and even there only with restricted accuracy.
- A fixing directly on or in the osseous tissue requires that the patient has to undergo an additional surgical intervention.
- The reference bodies (and possibly the whole rigid device) must remain fixed to the patient in an unchanged position from the time of image pick-up to the surgical intervention. In case of

a non-rigid or non-physical connection, time-consuming (and again failure-prone) intraoperative measuring and aligning work has to be performed.

- Generally, application is restricted to interventions in the region of easily accessible osseous structures and thus is normally unsuited for orthopedic surgery.

In the skull region, the systems described by Adams et al. and Kosugi et al. are suitable only with limited accuracy as freehand-guided intraoperative 3D position measuring devices for navigational purposes. These systems rely on artificial reference markers on the skin surface. (Natural landmarks normally cannot be unambiguously identified as reference points, neither in the tomographic image nor in the site of the operation) No possibilities exist for the planning and storing of orthopedic interventions and, further, only freehand-guided measurement probes are available). Thus, these systems cannot be employed as suitable devices in orthopedic bone surgery.

To sum up, it is to be noted that, presently, only relatively primitive intraoperative devices are available for a consequent transfer of an individually planned orthopedic-surgical intervention in osseous structures. Consequently, an individually adapted hip-joint endoprosthesis, to be implanted without cement, is rendered absurd by a freehand-guided cutting in the intraoperative prepa-

ration of the seat of the prosthesis. The technology of bone treatment has been lagging behind the technology of implant manufacture. This has resulted in imprecise preparations of the seat of prostheses with point-shaped force transmission and movement between bone and prosthesis. The same applies to individually planned repositioning osteotomies (being nonetheless relatively uncritical in the region of tibia and femur). For some considerably more complicated and critical interventions, e.g. in the region of the spinal column and the pelvis), there are no orientation and positioning devices available at all.

Further, efforts are being made to make use of robot technology for thus obtaining improved devices for faster, more accurate and less burdensome interventions also in the region of osseous structures.

Most of the known methods work after the above outlined reference body principle with preoperative image acquisition and are principally impaired by the above mentioned disadvantages. The endeffector is moved and positioned by a robot or manipulator (cf. e.g. Kwoh et al.: A robot with improved absolute positioning accuracy for CT-guided stereotactic brain surgery. IEEE Transactions on Biomedical Engineering, Vol. 35, No. 2, Feb. 1988; Taylor et al.: Robot total hip replacement surgery in dogs. IEEE Engineering in Medicine & Biology Society 11th annual international conference 1989, pp. 887-889; Reinhardt et al.: Robotik für Hirnoperationen, Polyscope plus No. 6, pp. 1, 5-6).

Some methods are executed with intraoperative image acquisition (particularly biplanar X-ray projection images) and suitable targeting and calibrating devices which appear in the image. By use of the known relationship between the targeting device and the robot (the targeting device being fixed e.g. in the robot gripper) and the relationship - defined by intraoperative X-ray images - between the targeting device and the X-rayed part of the body (the "object", as e.g. an osseous structure), it becomes possible to transform positioning processes or movements, having been defined in the coordinate system fixed to the object, into movements or positional vectors in the basic coordinate system of the robot (cf. e.g. Lavallée: A new system for computer assisted neurosurgery. IEEE Engineering in Medicine & Biology Society 11th annual international conference 1989, pp. 887-889; Jakobi et al.: Diagnosegesteuerte Therapierobotertechnik - medizinische und biomedizinische Aspekte, Z. Klin. Med. 45 Vol. 6, 1990, pp. 515-519).

In the region of soft tissues, the principal systematics of a fixedly defined spatial relationship between the image acquisition device and the positioning device for the endeffector has already become established in two cases (extracorporal shock wave lithotripsy, i.e. ultrasonic tomographic imaging or bipolar X-ray imaging with selection of the intracorporal target point in the image and semiautomatic positioning of the shock wave focus; mammabiopsy, i.e. bipolar X-ray imaging with identification of the target point in the image and semiautomatic po-

sitioning of the biopsy cannula). No comparable techniques are known in the field of orthopedic surgery of osseous structures.

In a further approach, it is tried to accomplish the identification and positional detection of osseous structures in orthopedic interventions by optical pattern detection and then, using a robot, to display cutting paths by a laser beam, to position tool guiding devices, to perform work on the bone directly etc. (Prasch: Computergestützte Planung von chirurgischen Eingriffen in der Orthopädie, Springer Verlag 1990). To this purpose, contours of the respective osseous structure which have been detected with the aid of a computer in biplanar intraoperative X-ray projection images, are compared to and, as far as possible, made congruent with 3D-CAD models of this structure which have been reconstructed from tomographic images and stored in the computer. If the orientation of the basic coordinate system of the robot and that of the X-ray device relative to each other are known, the robot can be moved according to its programming made corresponding to the 3D model in the CAD system. In the above mentioned publication, repositioning osteotomy is mentioned as an exemplary application. This system has not been realized yet.

In conclusion, it is to be stated that none of the above mentioned robot systems is suited for routine use in the field of orthopedic surgery of osseous structures. Systems which demand intraoperative X-ray images are disadvantageous for the above rea-

sons. Due to the inherent technical (including also safety measures), organizational and economic necessities, the use of robots has to be limited to surgical interventions which require spatially complex treatment movements which can be carried out only via narrow access openings, or to interventions which for some other medical or surgical reasons cannot or not efficiently be performed without the aid of manipulators and robots. (The much-quoted repositioning osteotomy in the femur or tibia region does not count among these).

It is an object of the invention to allow a treatment of osseous structures for any desired orthopedic interventions (i.e. also complex and possible novel interventions) which is safe, fast, exact and is defined according to the surgical planning. The term "treatment" is understood to comprise not only the treatment of an osseous structure by suitable tools (cutting, boring, milling device) but also other forms of treatment such as e.g. invasive measuring and scanning of osseous structures by corresponding measuring devices.

For solving the above object, there are proposed, in accordance with the invention, a method according to claim 1 and a template according to claim 3 which is preferably produced according to claim 5.

By the invention, intraoperative measuring and positioning periods shall be minimized by shifting them into the preoperative planning phase and working steps requiring X-ray imaging shall generally be

rendered unnecessary. For complex surgical interventions, quick and easy intraoperative access to a manipulator or robot as a tool for assistance in the surgical intervention shall be made possible.

According to the invention, the central functional element is a so-called individual template by which parts of the surface of an arbitrary osseous structure which is to be treated and is intraoperatively accessible to the surgeon, are copied as a negative image without undercut and in a mechanically rigid manner, so that the individual template can be set onto the osseous structure in a clearly defined position and with mating-engagement.

According to the inventive method, there is used a split-field device (e.g. a computer or a nuclear spin tomograph) by which split images are produced of the layers extending through the body of the living organism and containing the osseous structure, and from these split images, data regarding the three-dimensional shape of the osseous structure and the surface thereof are obtained. In the preoperative planning phase, these data are used as a basis for defining, within the coordinate system fixedly positioned relative to the osseous structure, a rigid individual template which, completely or by segments (but at least by three intraoperatively clearly identifiable abutting points), copies the surface of the osseous structure in such a manner that the individual template can be intraoperatively set onto these - then freely exposed - contact faces or points in exclusively one clearly defined position

in form-closed manner. Thus, when mounting the individual template, an individual abutting behavior is observed in all six spatial degrees of freedom. Therefore, quick and reliable identification and detection of position is possible intraoperatively. In the invention, the inter- and intra-individual variants of the shape of osseous structures, which pose a problem in other systems, guarantee a safe and clear intraoperative identification and detection of position.

Further, the invention is characterized in that the cutting, boring, milling and other treatment steps which in the preoperative surgical planning phase are three-dimensionally charted in said coordinate system fixed relative to the osseous structure, can be clearly defined in or on the individual template in form of guide means or reference or flange engagement points for standardized tool guides, which can be performed directly in or on the template body relative to the bone. Intraoperatively, this situation, which in surgical planning is precisely defined in three dimensions and simulated, is realized by simply setting the individual template onto the exposed surface of the bone. Time-consuming measuring and aligning work is thus shifted into the preoperative phase. Working steps which involve intraoperative X-ray control can be omitted.

Using the template of the invention allows a treatment of osseous structures for any orthopedic intervention (i.e. also complex and possible novel interventions) which is carried out in a safe, fast and

precise manner and is defined according to the surgical planning while it is not necessary anymore to intraoperatively check the orientation of the treatment tool. Intraoperative measuring and positioning periods are minimized by being shifted into the preoperative planning phase and working steps requiring X-ray imaging have become unnecessary. For complex surgical interventions, a possibility is created for quick and easy intraoperative access to a manipulator or robot employed as an auxiliary tool in the surgical intervention.

The invention comprises the following features and characteristics:

1. By 3D reconstruction of a tomographically imaged object, particularly of the osseous structures of a living human, and by visualizing this reconstruction on an output medium, particularly a computer monitor, and particularly by using a computer system or a computer-based display and construction system, there is generated a three-dimensional negative mold of parts of the individual natural (i.e. not pre-treated) surface of the osseous structure intraoperatively accessed by the surgeon.
2. The above negative mold can reproduce a cohesive region or a plurality of geometrically non-abutting partial segments of a bone surface and is constructed in a cohesive, mechanically rigid basic body (the individual template). The overall geometry of the basic body is also adapted

to the spatial conditions of the surgical access so that it will not overlap with any structure.

3. By use of the computer-based representation of the three-dimensional reconstruction of the osseous structure, the treatment of the bone can be planned. For this treatment, any suitable tool guides, particularly drill sleeves, parallel guides, saw templates, 2D- and 3D-profiling milling devices can be provided. These tool guides, connecting elements, surfaces or points can be provided in/on the basic body of the individual template, which relative to the 3D reconstruction of the osseous structure are oriented or constructed in such a manner that the tool guides, which here can be coupled (releasably or non-releasably) in a mechanically rigid manner, will effect a three-dimensional guiding of the treatment tools or measuring devices exactly as provided by the surgical planning.
4. According to the course of procedure described above under item 3, also the basic body of the individual template can have connecting elements, surfaces or points arranged thereon, which can be releasably coupled in mechanically rigid manner to the gripper piece of a manipulator and thus preoperatively define the position of the gripper piece of the manipulator relative to the three-dimensional reconstruction of the osseous structure.

5. Prior to the intervention and starting from the home position described above under item 4, a spatial treatment or moving program for the gripper piece of the manipulator can be defined in the gripper piece coordinate system in a spatially determined relation to the three-dimensional reconstruction of the osseous structure and be programmed in a computer-based procedure.
6. Further, prior to the intervention and starting from the home position described above under item 4 and also in a spatially determined relation to the three-dimensional reconstruction of the osseous structure, it is possible that, for the gripper piece of the manipulator, a desired spatial and chronological dependence on the 3D position and the mechanical 6D impedance can be defined in the gripper piece coordinate system and be programmed in a computer-based procedure.
7. The basic body of the individual template mentioned above under item 2., comprising the negative mold, the connecting elements, surfaces or points is produced preoperatively by use of a computer-based manufacturing device (particularly by NC milling and/or stereolithography). During the preparation of the surgical procedure, the tool guides provided in the surgical planning are preoperatively mounted on the basic body of the individual template.
8. During the surgical intervention, the above treatment steps defined in the phase of surgical

planning can be exactly transferred since, relative to the osseous structure, the tool guides can be brought exactly into the positions defined during the surgical planning phase (i.e. the manipulator gripper piece can be brought into the home position defined in the surgical planning phase). To this purpose, the individual template with the faces of the negative mold is set under mating engagement onto the then exposed bone surface, which is done without any further intraoperative devices (particularly without measuring devices such as 3D measuring arms or the like) and without intraoperative measuring and positioning work.

9. When optionally using a manipulator, the moving program defined during the preoperative planning phase in the computer system through gripper and workpiece coordinates, or, respectively, the 6D impedance variation space defined in the same manner, is converted after the intraoperative mounting of the individual template coupled to the gripper piece, and then will be available during the surgical intervention.
10. As outlined under item 9 above, the treatment and moving program defined under item 5 can be automatically reproduced in an exactly defined manner relative to the osseous structure or be manually released by pieces. The moving and treatment space defined according to items 6 and 9 is intraoperatively reproduced in an exactly defined manner relative to the bone through the

spatial and chronological dependence on the variation of the mechanical 6D impedance of the manipulator guided by the surgeon on its gripper piece.

11. The guide means of the template for limiting the movement of a treatment device during the treatment of an osseous structure as provided by the surgical planning allows e.g. vertebral osteotomy using a vertebral-osteotomy template with a rear contour analogous limitation for the cutting depth. This limitation for the cutting depth, which requires a guide path for the guide means which corresponds to that limiting edge of the cut through the osseous structure which faces away from the template, can guarantee sufficient accuracy by exact positioning and guidance of the tool simply by employment of an (individual) template conforming with the osseous structure in mating engagement.
12. The consideration of the spatially diametrical bone surface with respect to the "rear contour analogous limitation for the cutting depth" by which, when guiding the cutting, the rear boundary of the bone is considered corresponding to the projected cutting curve and the rear side of the bone, and is not exceeded by the saw blade. What is again of functional importance here is the use of an individual-template basic body so as to exactly and clearly position the cutting depth limitation during the surgical intervention.

13. 3D copying milling device for the cleansing of medullary space or for the milling of predetermined shapes in osseous structures, characterized in that the geometrical data provided for the 3D copying milling device reproduce individual geometrical conditions of the three-dimensional reconstruction of the tomographically imaged osseous structure. Also here, it is functionally important to use an individual-template basic body so as to exactly and clearly position the 3D copying milling device during the surgical intervention.

Embodiments of the invention will be explained in greater detail hereunder with reference to the drawings. Throughout the Figures, identical reference numbers are used for identical parts in the different embodiments. The Figures show some exemplary embodiments which are merely provided for explaining the invention but, due to the various possible applications of the invention, cannot depict the invention in an all-inclusive manner.

Figs. 1 to 5

show a first embodiment of the invention with an individual template, adapted to a vertebra, for guiding a tool, which in this case is a drill for application of bores for pedicle screws into the vertebra,

Figs. 6 to 8

show a further embodiment of an individual template and its intraoperative handling and use,

Fig. 9 shows an individual template which is an alternative to the embodiment according to Figs. 6 to 8,

Figs. 10a to 10d

show a further embodiment of an individual template for hip-joint individual endoprostheses,

Fig. 10e

shows an alternative to the individual template according to Figs. 10a to 10d,

Figs. 11a to 11d

show a further possible application of an individual template for use in scoliosis correction by repositioning osteotomy in the region of individual vertebrae,

Fig. 11e

shows a further possibility for using an individual template for scoliosis correction by repositioning osteotomy in the region of individual vertebrae,

Fig. 12 shows the use of an individual template for osteotomy in the region of the thoracic limb,

Figs. 13a to 13d

show a further individual template for preparation of a prosthesis seat of a knee-joint head prosthesis,

Figs. 14a to 14c

show an individual template provided with a copying milling device,

Fig. 15 and 15b

show an example of the use of an individual template for robot-assisted treatment of osseous structures,

Figs. 16a to 16e

show a further example of the use of an individual template for robot-assisted treatment of osseous structures,

Fig. 17 shows a further example of robot-assisted treatment,

Fig. 18 is a flow chart for illustrating the method of computer-aided and computer-integrated alignment of treatment tools for the treat-

ment of osseous structures in orthopedic surgery, and

Fig. 19 is a flow chart for illustrating the method for alignment of treatment tools for the robot-assisted treatment of osseous structures in orthopedic surgery.

Figs. 1a, 1b, 2a, 2b, 2c, 3a, 3b, 4, 5a, 5b, 5c show an individual template 4 for application of two bores in a vertebra. Each of the bores serves for the mounting of a pedicle screw which shall be screwed through the (left or right) pedicle into the body of the vertebra, as it is usually done for the anchoring of a fixateur-intern within a scoliosis operation. For reasons of stability, the screw shall be secured in the cortical substance (i.e. the outer, more compact osseous layer). On the other hand, the bore and the screw shall injure neither the spinal cord extending in the adjacent spinal canal nor the spinal nerves issuing from the intervertebral canal, and penetrate through the cortical substance of the ventral side of the vertebra only so far that it does not yet ventrally issue from the body of the vertebra. According to these requirements, the bores are preoperatively clearly defined in space by the entrance and end points and the diameter, and the screw is defined by the diameter and the length, which is done e.g. using CT images.

The method of the invention will be described hereunder by way of an example which also stands for other, comparable interventions:

The vertebra and the regions of the structure relevant for the surgical planning (the osseous structure 17 in general) are scanned by a tomographic method as already described, are reconstructed in three dimensions, and the thus obtained 1:1 model is visualized by a suitable medium (e.g. CAD system). Also a model of the osseous structure 17 made from any mechanically rigid model material, which has been produced in the master mold technique by machining or any other desired production method (from UV curable polymer material, e.g. by means of stereolithography), can serve as a basis for the further method steps described hereunder. Methods for the construction of an individual template e.g. by means of a physically rigid model of the osseous structure (e.g. of plastics, wax or metal) and by a plastically deformable, curable material which is machinable in the cured condition, can be used for modelling and producing an individual template.

Particularly the method based on a computer-assisted CAD model will be described hereunder:

The osseous structure 17 (i.e. the vertebra) is reproduced in a CAD system as a computerized model. For example in the region of the transverse processes and the vertebral arc (Fig. 2) (or also of the transverse process and the processus spinosus) (Fig. 5) or of the processus spinosus and the vertebral arc or ...) parts of the bone surface which are intraoperatively accessible to the surgeon are defined in the model as contact faces 1 for the individual template 4. After reversal of the normal line

of the surface (Fig. 3: 2 and 3), the defined contact faces 1 are used (as a negative, a "cast", "reproduction") for a basis for the individual template 4 to be constructed in the coordinate system fixed relative to the model. To this effect, the contact faces 1 are first connected to a mechanically rigid construction adapted to the environment and the desired overall function, i.e. to the individual template body, so that the individual template 4, via the conventional surgical access (Fig. 4: sketch of a dorsal surgical access in an intervention for scoliosis correction), can be set directly onto the exposed bone surface in a clearly defined manner as provided by the invention, without colliding with other structures in the surgical region. To achieve this, the individual template 4 is of such a configuration that e.g. the contact faces 1 are defined without undercut and that, possibly, recesses 5 (cf. Fig. 5) are provided for structures in the vicinity of the contact faces 1. Thus, the individual template as a whole is adapted to the surgical site. Further, in this individual template, the tool guide, i.e. the drill guide, is mounted directly on the template body 6. To this purpose, two bores 7 are provided in the body of the individual template, on whose bore axes 8 there are arranged the entrance and end points 9,10 of the bores defined in the bone model according to the surgical planning, and which are provided with drill sleeves 11 which are each unambiguously positionable in the bores. With a known drill length 12, these drill sleeves define drill depths and diameters which, in length and inner diameter, are exactly adapted to the surgical

planning. Further, in or on the individual template body, there are provided bores, threaded bores or other receiving portions for connecting elements, allowing fixation of a universal gripper 14, which can also be reusable, or e.g. of a holding arm 15 which is fixed to the operation table and can be freely positioned and locked. Additionally, clamping devices or screw connections (e.g. 19) can be provided for intraoperative fixation of the individual template 4 onto or to the osseous structure 17.

After generation of a corresponding machine program, the individual template 4 is produced by machining on a NC milling machine, favorably from plastics, e.g. plexiglass (PMMA) or also other materials, e.g. metal, or by a master mold technique, e.g. by stereolithography (or a similar procedure as described e.g. in Eusemann, Schnell zum Modell durch Rapid Prototyping, VDI nachrichten No. 17, April 26, 1991, p. 26 and in DE 39 33 142) from UV curable polymer. When machining is provided, e.g. in case of the pedicle-screw individual template 4, use can be made of a largely prefabricated semi-finished product which in NC treatment simply has to be provided with the contact faces 1 and the bores 7 each of which are individually defined. During the surgical intervention, the drill sleeves 11 are brought quickly and in a precisely defined manner into that position relative to the bone 17 which before has been determined in the surgical planning; according to the invention, this is accomplished by setting the individual template 4 onto the vertebra (i.e. onto the contact faces in the region of the trans-

verse processes and the vertebral arc). As provided by the invention, the bores 7 can be generated directly by insertion of the drilling tool into the drill sleeves 11, wherein the diameter 16 and the entrance and end points 9,10 of the bores in the osseous structure of the vertebra 17 are defined by the preoperative planning and can be clearly reproduced intraoperatively.

The usefulness of semi-finished products has to be examined depending on the respective surgical intervention. Semifinished products specifically suited for the intervention can be stored, in the CAD system, as a Macro (also parametrically) in libraries together with standard tool guides, standard tools, surgical fixing elements such as screws, fixateur-intern or -extern, other osteosynthesis instruments, grippers and holding arms up to robot and manipulator libraries. Also the storage of libraries with physiological or pathological osseous structures as well as standard surgical accesses in the CAD computer system can be of advantage. Then, in the phase of surgical planning, the mentioned individual components can be combined with each other, adapted to each other and positioned relative to each other in any desired manner in the coordinate system fixed relative to the computerized model of the osseous structure. By a clearly defined mechanical connection and positioning of the individual components relative to each other and to the basic body of the individual template, which relative to the osseous structure has a clearly defined spatial position because of the contact faces, also the spatial posi-

tion and orientation of the individual components relative to the bone is known and can be clearly reproduced intraoperatively by mounting the individual template.

Figs. 6a, 6b, 7a, 7b and 8 illustrate an embodiment of the method exemplified by the use of the principle of the individual template in a repositioning osteotomy in the region of the trochanter minor. The contact faces 1 of the mechanically rigid template body 6 of the individual template 4 clearly define the position of the template relative to the osseous structure 17. Thereby, also the position of the cutting planes according to the surgical planning (Fig. 7) can be intraoperatively reproduced by mounting the individual template 4. The individual template 4 can optionally be provided with a universal gripper 14. Also a fixation (nails, screws and the like) 19 on the bone 17 can be optionally performed. Further, through a drill sleeve 11 and a bore 7, the bore defined in the surgical planning (Fig. 7) and having the bore axis 8 and the entrance and end points 9,10, can be intraoperatively reproduced for fixing a fixateur-intern 21 as shown in Fig. 8. Fig. 9 shows an alternative simple individual template 4 (only saw template) for repositioning osteotomy.

Also the cutting plane which forms basis of the construction of e.g. hip-joint individual endoprostheses can be exactly reproduced by means of the individual template. Figs. 10a to 10d show an embodiment for a corresponding individual template 4. (Fig. 10 again shows a simplified alternative). As

will be described hereunder with reference to this embodiment and as shown in Figs. 10a to 10d, the individual template 4 can also be the basis for further, additional individual templates 27 which need not have contact faces 1 to the osseous structure 17 but are (rigidly) connected to the basic individual template 4 by defined flange engagement points 28. By use of such flange engagement points 28, also other additional devices, e.g. a parallel guide 26, can be coupled. Also a rear contour analogous limitation 24 of the cutting depth can be provided in/on the individual template 4 or/and the additional individual template 27. To this purpose, the cutting contour of the rear side of the osseous structure 17 with the respective cutting plane 20 is reproduced in such a manner in the individual template 4 (or, respectively, in the additional individual template 27) in the form of the rear contour analogous limitation for the cutting depth that the saw 25, guided in parallel, whose housing is rigidly connected to a guide pin (or guide cam) which slides along the rear contour analogous limitation for the cutting depth, cannot move beyond the boundary of the osseous structure in rearward direction. When mounting a fixateur-intern 21, the bores 19 applied for the fixation of the individual template can be utilized, if desired (Fig. 10d).

Figs. 11a to 11e illustrate, by way of example, the method of a scoliosis correction by a repositioning osteotomy in the region of individual bodies of the vertebrae. Further, the method of the rear contour analogous limitation 24 of the cutting depth, an

alternative option of a parallel guide 26 for the sawing tool 25 and the method for mounting a fixateur-extern through a ventral access (Fig. 11e), are explained in greater detail. In the method of the scoliosis correction by a repositioning osteotomy in the region of individual vertebrae, it is provided according to the invention that, in the surgical planning phase, clearly defined bone wedges are cut from also defined bodies of the vertebrae, the spinal column as a whole is aligned and is temporarily fixed by known methods of osteosynthesis (from ventral and/or dorsal, Fig. 11e). Thus, completely new possibilities for operation and therapy are opened for scoliosis therapy, since, in the above manner, a scoliosis correction can be effected up to an angle of about 45° (according to Cobb) (Fig. 11d) without a lasting stiffening of the spinal column (and without destruction of the intervertebral discs due to the therapy).

In addition to the contact face 1 between the individual template 4 and the body 17 of the vertebra, a rear contour analogous limitation 24 for the cutting depth and a saw 25, being guided exactly parallel in the respective cutting plane, are required. The whole design and the manufacture are performed, as already described, on the basis of tomographic images of the spinal column and assisted by a computer, in the CAD system, and manufacture is carried out by one of the above mentioned manufacturing methods. Two guide pins 23, rigidly connected to the housing of the sawing tool 25, are moved along two guides, i.e. the rear contour analogous limitations 24 for

the cutting depth. These will image the form of the rear side of the body 29 of the vertebra in such a manner that, when cutting is executed with a saw blade guided in parallel according to Fig. 11a, the tip of the saw blade exactly follows the rear surface of the body of the vertebra and linearly cuts through the cortical substance. To this effect, the geometry of the sawing tool 25 along with the guide pins 23 and the geometry of the saw blade must be known in the phase of surgical planning. Further, a cutting plane 20 must be defined, and a corresponding parallel guide 26 of the saw tool 25 has to be provided intraoperatively. A parallel guidance can be safeguarded e.g. in the manner shown in Figs. 11a to 11c.

The individual template 4 can be optionally fixed, as shown at 19, on the body of the vertebra and be provided with a universal gripper 14. If a universal parallel guide (as shown e.g. in Fig. 10b) is to be employed, corresponding flange engagement points 28 have to be defined in the surgical planning phase. In this case, a sole rear contour analogous limitation 24 for the cutting depth, accordingly having a sole guide pin 23, will be sufficient.

Fig. 11e shows a method by which a fixateur-extern for alignment and temporary fixation of the spinal column after a ventral repositioning osteotomy in the region of individual bodies of the vertebrae, can be fixed solely through the ventral access and can be mounted in a non-invasive manner from dorsal. To this effect, bores 7 are formed from ventral

through the body of the vertebra and the pedicles by use of an individual template 4 and drill sleeves 11. Then, a surgical threaded bar 30 is screwed into each of these bores until the head 32 of the threaded bar is flush with the ventral surface of the body of the vertebra. The threaded bars 30 are characterized in that each of them comprises a mandrel-like tip 31 which, when the threaded bars 30 are screwed into place, penetrate the layers of tissue dorsally abutting the vertebra, and in the screwed condition project so far beyond the dorsal surface 33 of the body that a fixateur-extern 22 adapted to them can be fixed to them and, thus, alignment and fixation of the spinal column can be performed from dorsal. Further, the threaded bar 30 is characterized in that a screwing tool can be applied in the region of the head 32 of the threaded bar (e.g. an internal hexagon), while, however, the head 32 of the threaded bar has a smaller diameter or the same diameter as the inner diameter of the thread. Thus, the threaded bar can be removed from dorsal. Additional ventral fixations of the bodies of the vertebrae to the purpose of osteosynthesis can be performed by use of fixateur-intern (clamps, plates and so on; possibly also by absorbable material) as commonly used to that purpose.

As a further example, Figs. 12a and 12b schematically illustrate an application of the method using the individual template with alignment and definition of the cutting planes 20 and rear contour analogous limitation 24 for the cutting depth as performed in osteotomy in the region of the thoracic limb. The

line 24 of the body 6 of the individual template corresponds to that edge of the cutting plane through the osseous structure 17 of the thoracic limb which is facing away from template 4.

Figs. 13a to 13c schematically show an individual template 4 for the preparation of the seat for the knee-joint head prosthesis illustrated by way of example in Fig. 13d. The intraoperative procedure is as follows: The individual template 4 is set onto the bone 17 in a defined manner, abutting the contact faces 1. The drill sleeve 11 is inserted, and the bore with the bore axis 8 is formed in the bone. Subsequently, the drill sleeve is removed again. Then, the cut is formed along the cutting plane 20a. Then, the cut 20b can be performed free-handed at a right angle to cut 20a. (To this effect, also an additional template 27 can be provided). Thereafter, the groove (cut 20c) is milled or sawed (according to the geometry of the prosthesis), and then, cut 20d is formed along the lower edge of the individual template 4.

Using an individual template, almost any random devices can be brought into a clearly defined position relative to the osseous structure as provided by the surgical planning. Milling operations can be exactly planned and realized by a copying milling device which is set onto the osseous structure through a suitable individual template (and which can also reproduce geometries of osseous structures or reflect them in some other manner).

Figs. 14a to 14c schematically show the cleansing of the space of the femoral marrow from bone cement. The individual template 4 is intraoperatively set with the contact faces 1 onto the prepared bone. (Also for preparatory treatment, individual templates can be provided). The individual template 4 together with the additional device 41 coupled thereto by defined flange engagement points 28 defines the spatial orientation of the axis 42 of the milling device relative to the bone 17. The plan-parallel guide 36 of the additional device 41 limits the movements of the milling tool (or the milling head) in a plane perpendicular to the axis 42 of the milling device, and, further, the linear guide 37 of the additional device 41 limits the movements in the direction of the axis 42 of the milling device. The individual template 4 also comprises a cavity which, in the manner illustrated in Fig. 14a, is a copy 39 of the medullary space 40 but, as compared thereto, is enlarged in radial direction (relative to the axis of the milling device) by the factor of the difference of diameters ($D_{\text{GUIDE CAM}} - D_{\text{MILLING HEAD}}$). When the guide cam 23 is guided within this copy 39 of the medullary space, the medullary space is milled by the milling head 35 on the corresponding locations. In the surgical planning phase, the overall individual template 4 along with the flange engagement points 28 for the additional device 41 - with the geometry of the milling tool 38 and the additional device 31 being known, and on the basis of tomographic images of the osseous structure 17 and the medullary space 40 - is constructed and manufactured in such a manner that, during the operation

and in the above described manner which is illustrated in Fig. 14a, the whole medullary space 40 can be milled and the bone cement can be removed without injuring the compact outer structure of the bone. This method allows three-dimensional milling and cleansing of the medullary space in one working phase and in a clearly defined manner in accordance with the surgical planning.

Further applications are e.g. the triple repositioning osteotomy of the pelvic bone, fixations in the region of the lumbosacral joint, and limited resections of tumorous bone tissue.

The use of a robot or manipulator can be advantageous in case of very small access openings or spatially complex treatment processes (e.g. in triple repositioning osteotomy of the pelvic bone or complex milling treatment). Fig. 19 describes the principal method in diagrammatic form.

Figs. 15a and 15b show a first embodiment for the use of an individual template for robot-assisted treatment of osseous structures in orthopedic surgery. In the surgical planning phase, on the CAD system, the gripper 48 of a robot mechanics 49 stored in the macro library of the CAD system can be connected, with the contact faces 1, to the computerized model of the osseous structure 17 by a non-positive and torque-coupling connection to the individual template 4. In doing so, the simulated position of the robot gripper 48 in the coordinate system 43 fixed relative to the osseous structure 17

(or, respectively, the transformation relationship between the coordinate system fixed 44 relative to the robot gripper and fixed 43 relative to the osseous structure, when the individual template 4 is mounted on the bone 17 and is connected to robot gripper 48 in a defined rigid manner) is computed and stored as a starting position for simulation and program generation of the whole treatment procedure which, if desired, is performed with different treatment tools 47. The transformation relationship, changeable over time during the treatment procedure, between the robotic end effector 47 or the robot gripper coordinate system 44 and the coordinate system 43 fixed relative to the osseous structure 17, is respectively planned, computed, simulated and stored or documented in the CAD system. This includes the possibility of a positioning of laser pointers, tool guides, measuring probes, and of a direct treatment of the osseous structure by drills, milling devices, saws, lasers, ultrasonic applicators and others. Under the safety aspect, it would also be reasonable to define and program allowed and prohibited moving regions.

Using the individual template 4, fixed to the gripper 48 of robot 49 according to the surgical planning, the robot, during the surgical intervention, can quickly and reliably detect the spatial position of the osseous structure by the teach-in method (Fig. 15a). In the mounted condition of the individual template 4, the parameters of the joint or the positional measuring data of the e.g. six axes of the robot 49 can be used for determining the trans-

formation relationship between the basic coordinate system 45 of the robot and the coordinate system 43 fixed relative to the osseous structure 17. On the basis of this transformation relationship, the treatment steps, defined during the surgical planning phase in the coordinate system 43 fixed relative to the osseous structure 17 (i.e. the transformation relationship, changeable over time during the treatment procedure, between the robotic end effector 47 or the robot gripper coordinate system 44 and the coordinate system 43 fixed relative to the osseous structure 17), can be computed after spatial fixation 46 (holding arm, other fixateurs-extern) of the bone in the basic coordinate system 45 of the robot. To this purpose, the transformation relationship, changeable over time, between the robot gripper coordinate system 44 and the basic coordinate system 45 of the robot, and thus the movement of the endeffector 47 (or gripper 48, respectively) is computed in the basic coordinate system 45 of the robot. The intraoperative transfer of the treatment procedure can be carried out e.g. by robot-assisted positioning of tool guides, marking of cutting planes by laser beam, or also automatic treatment by robot-guided endeffectors, e.g. saws/drills/milling devices and so on. Further, the position of the treatment tool 47 relative to the osseous structure 17 can be intraoperatively displayed in the picture of the model on a computer monitor 57 and can be visually controlled by the surgeon.

Figs. 15a and 15b schematically show the described method. The description of the geometry of the

treatment tool 47 in the coordinate system of the robot gripper 44 has to be known and has to be identical with the one defined in the surgical planning. The same holds true for the transformation relationship between the robot gripper 48 or 44 and the individual template 4 (among others, defined by the flange engagement points 28). The robot must be newly calibrated in each case prior to the operation. CAD models for preoperative simulation and off-line programming of diverse robots are available on the market.

Figs. 16a to 16e schematically show the method by way of example in connection with an operation for applying an individually adapted hip-joint prosthesis. Further, the Figures show other embodiments for individual functional elements, e.g. fixation of the individual template 4 to the bone 17a through a connecting element 18, establishing a reference between the coordinate system 43 of the bone and the basic coordinate system 45 of the robot by use of a reference bore 52 provided with an adjusting-spring groove, spatial fixation of the osseous structure 17 through flange engagement points 28 of the individual template 4. According to Fig. 16a, the individual template 4 is set with the contact face 1a onto the femur bone 17a and is fixed by two wires. The bone 17a and the individual template 4 are spatially fixed through flange engagement points 28 by means of a holding arm (or other fixateur-externs) 46 clampingly fixed e.g. to the operating table. The robot 49 whose gripper piece 48 carries e.g. a shaft end having a defined geometry and being provided

with an adjustment spring, detects the relative position of the osseous structure 17 in the basic coordinate system 45 of the robot by the teach-in method through insertion of the referencing body (shaft end with adjustment spring) into the referencing bore 52 of the individual template 4. Thereafter, diverse treatment steps such as osteotomies and preparation of the medullary space are performed, according to the surgical planning, directly (by treatment tools) or indirectly (by laser pointers, gauges and others) through the robot under permanent control by the surgeon. (To these steps belong, for instance, as shown in Fig. 16b, the positioning of a simple universal saw template according to the cutting planes 20 defined in the surgical planning, performed by the robot 49, and, as shown in Fig. 16c, the treatment of the medullary space by a milling tool 47 guided by robot 49 according to the surgical planning). Also the preparation of the acetabulum 51 can be carried out in a similar manner. To this purpose, the pelvis 17b is clampingly fixed from outside in the region of the palpable bone points as rigidly as possible and non-invasively. By an individual template 4b which in the region of the edge of the acetabulum can be mounted in a defined manner with the contact surface 1b, the robot 49 determines the spatial position of the osseous structure 17 in the basic coordinate system 45 of the robot. Then, the treatment, e.g. by means of a milling tool, is executed as defined by the surgical planning. In this manner, it is possible e.g. to define an optimum thickness of the remaining bone and to avoid unintended perforation of the bottom of

the acetabulum. Fig. 16 just gives one example of the many possible applications of the instant method in the field of surgical treatment of osseous structures.

The method for treatment of osseous structures by means of "virtual individual templates":

If, during the phase of surgical planning on the CAD system, the "allowed" moving range 50 for treatment tools is structured, defined and programmed with suitable precision in the coordinate system 43 fixed relative to the osseous structure 17, it is possible to define, on the basis of respective limitations of the moving space, respectively one access corridor 55 and, adjoining it, a "virtual" tool guide 56 aligned and positioned according to the surgical planning. In this manner, a reproducible treatment of the bone can be accomplished also in that the treatment tool (saw, drill, milling device or the like) is intraoperatively fixed to the gripper piece 48 of a passive, impedance-variable manipulator 49 and is manually moved by the surgeon. Fig. 17 serves for schematic illustration of the method. When approaching, within the operation site, the osseous structure 17 to be treated, the surgeon is guided by defined impedance variations of the manipulator (increase of the impedance when performing movements in the direction of the limitation of the access corridor) until, directly before contact of the treatment tool with the osseous structure 17, movement is possible only along the virtual tool guide ("virtual template") defined according to the surgical plan-

ning. The impedance variations can be effected or controlled by computer-assisted brake systems or actuators in the individual joints and degrees of freedom of the manipulator 49. For the force- and position-controlled system, there is required a 6D position and force-moment measurement (e.g. in the individual joints or through a 6D force-moment sensor 53 in the gripper piece 48 of manipulator 49).

The steps during the planning of the surgical intervention on the CAD system are the following:

- Definition of the individual template 4 with the robot gripper piece 48 in the coordinate system 43 fixed relative to the osseous structure 17; manufacture of the individual template 4.
- Definition, calculation and storage of the treatment procedure in form of an allowed moving space 50 in the coordinate system 43 fixed relative to the osseous structure 17.

Intraoperative steps are:

- Fixation 46 of the osseous structure 17.
- Determination of the spatial position of the osseous structure 17 in the basic coordinate system of the robot by use of the individual template 4 mounted in the gripper piece 48 of the robot (shown in interrupted lines).

- Transformation of the allowed moving space, defined in the surgical planning phase in the coordinate system 43 fixed relative to the osseous structure 17, into the basic coordinate system 45 of the robot.

- Movement of the gripper piece 48 of the robot along with the treatment tool 47 by the surgeon; in doing so, counterforces and -moments (impedance variation) are generated by the manipulator in dependence on the position of the control points 54 and the forces and moments exerted by the surgeon; when the control points 54 reach the limiting faces of the moving space, the vectorial components of the applied forces and moments which would lead to a movement of the control points in vertical direction to the limiting faces of the moving space and out of the moving space, are neutralized by vectorially corresponding counterforces and -moments of the same amount. In the allowed moving space 50 and along its moving faces, the control points 54 (or the endeffector 47) can be moved freely or, respectively, assisted by a servo mechanism (i.e. with vectorially negative counterforces and -moments). Further, during the operation, the position of the treatment tool 47 relative to the osseous structure 17 can be displayed in the image of the model on a computer monitor 57 and can be visually controlled by the surgeon.

Claims

1. A method for the definition and reproduction of the positional relationship of a treatment tool or a treatment or measuring device relative to an osseous structure for orthopedic surgery, wherein
 - the osseous structure (17) is reconstructed,
 - on the basis of said reconstruction of the osseous structure (17), contact points and/or contact faces (1) are defined as abutment points for a mechanically rigid template (4) for guiding and aligning the treatment tool or the treatment or measuring device, said contact points and/or contact faces (1) being selected in such a manner that the template (4), when mounted on the osseous structure (17), abuts the osseous structure (17) in form-closed manner in exactly one spatially uniquely defined position,
 - the spatial position of the treatment tool, the treatment or measuring device relative to the osseous structure (17) is defined,
 - corresponding to the previously defined position of the treatment tool, the treatment or measuring device, fastening means are provided on or in the template (4), for fastening and/or guiding the treatment tool, the treatment or measuring device on the template (4),
 - the template (4), having thus been defined with respect to its interfaces with the osseous structure (17) on the one hand, and the

treatment tool, the treatment or measuring device on the other hand, is produced, and

- the template (4), provided with the treatment tool, the treatment or measuring device, is positioned on the osseous structure (17) on the contact points and/or contact faces (1) defined on the basis of the reconstruction of the osseous structure (17).

2. The method according to claim 1, characterized in that said reconstruction is performed on the basis of data which are obtained by non-invasive detection of the geometry of the osseous structure (17).

3. A template for alignment, positioning and guidance of treatment tools, treatment or measuring devices for treatment of an osseous structure, comprising

- a template body (6) comprising abutment points adapted to selected contact points and/or contact faces (1) of the osseous structure (17) for form-closed abutment on said contact points and/or contact faces (1) of the osseous structure (17),
- the template body (6) copying the surface of the osseous structure (17) as a whole or by segments, but at least by three intraoperatively uniquely definable abutment points, in such a manner that the template body (6) can be mounted on the osseous structure (17) in form-closed manner exclusively in exactly one spatially uniquely defined position, and

- fastening means for fastening the treatment tool, the treatment or measuring device to the template body (6) in such a manner that the treatment tool, the treatment or measuring device, when the abutment points of the template body (6) are in abutment with the contact points and/or contact faces of the osseous structure (17), is in a reproducible defined orientation relative to the osseous structure (17).
4. The template according to claim 3, characterized in that the template body (6) comprises guide means for limiting the movement of the treatment tool, the treatment or measuring device for treatment of the osseous structure (17).
 5. The use of a device for non-invasive tomographic imaging of osseous structures, particularly the use of computer or nuclear spin tomographic devices, for reconstruction of an osseous structure (17) in order to produce a template (4) mountable in form-closed manner onto the osseous structure (17), for mounting and/or guidance of treatment tools, treatment and/or measuring devices for treatment of the osseous structure (17).
 6. A method for the treatment of osseous structures in orthopedic surgery, wherein
 - the osseous structure (17) is reconstructed,
 - on the basis of said reconstruction of the osseous structure (17), contact points and/or

contact faces (1) are defined as abutment points for a template (4) for guiding and aligning a treatment tool, said contact points and/or contact faces (1) being selected in such a manner that the template (4), when mounted on the osseous structure (17), abuts the osseous structure (17) in form-closed manner in exactly one spatially uniquely defined position,

- the spatial position of the treatment tool relative to the osseous structure (17) is defined according to the surgical planning,
- corresponding to the position of the treatment tool previously defined according to the surgical planning, fastening means are provided on or in the template (4), for fastening and/or guiding the treatment tool on the template (4) according to the surgical planning,
- the template (4), having thus been defined with respect to its interfaces with the osseous structure (17) on the one hand, and the treatment tool on the other hand, is produced,
- the template (4) provided with the treatment tool is positioned on the osseous structure (17) on the contact points and/or contact faces (1) defined on the basis of the reconstruction of the osseous structure (17), and
- the osseous structure (17) is treated by guiding the treatment tool on the template (4).

7. The use of the method according to any one of claims 1 or 2, for identification, positional detection and treatment of osseous structures in orthopedic surgery.

8. The use of the method according to any one of claims 1 or 2, for identification and positional detection of osseous structures by use of a treatment device, particularly a computer-assisted manipulator, robot or the like.

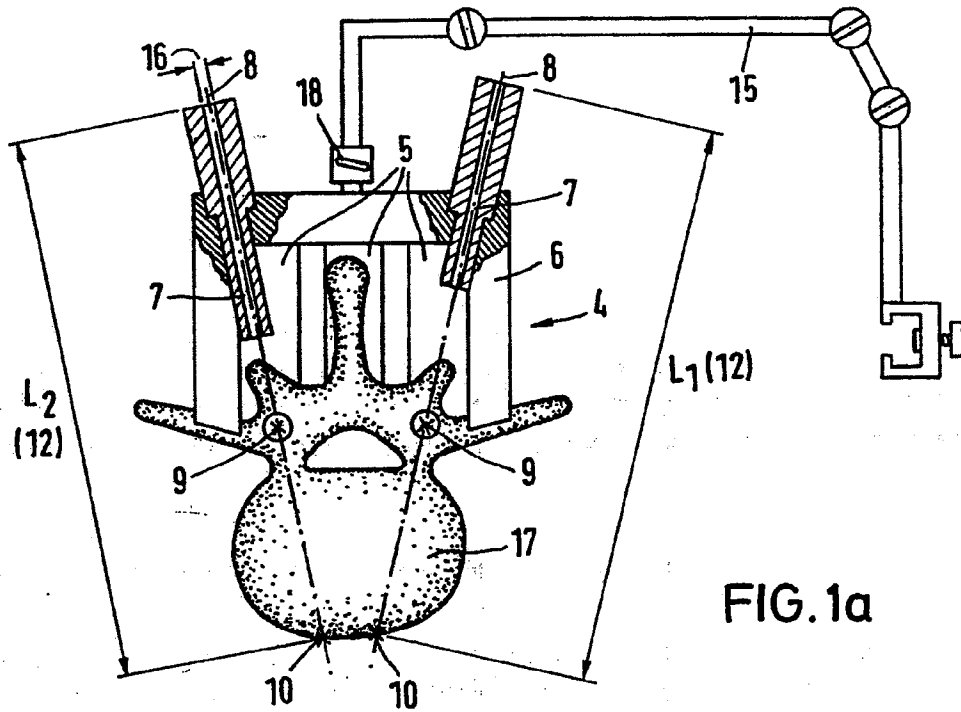

FIG. 1a

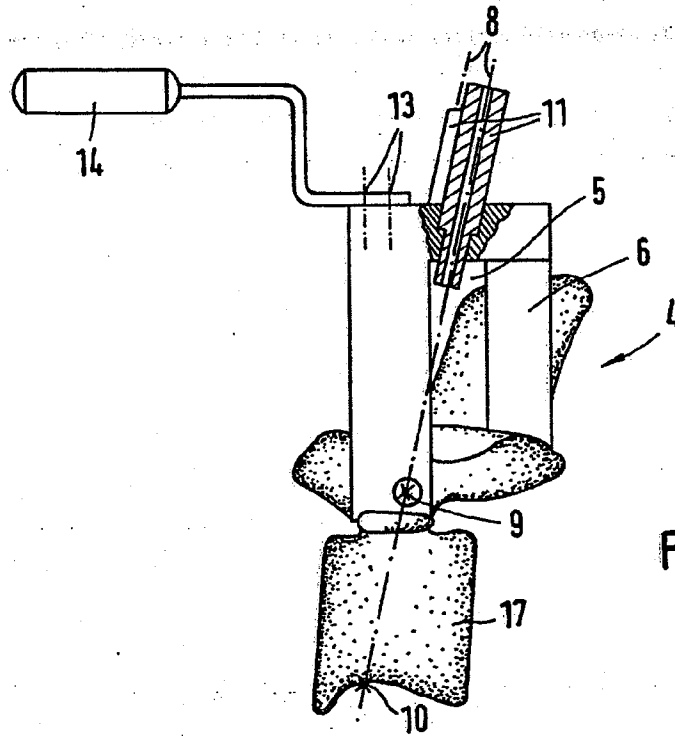

FIG. 1b

FIG. 2c

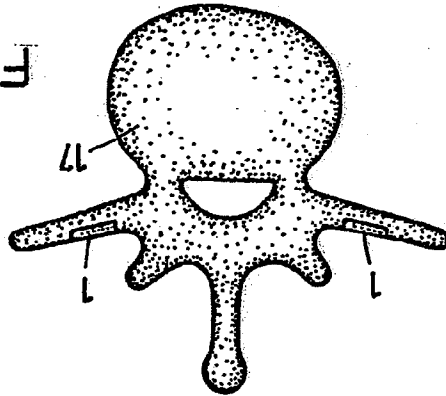

FIG. 2b

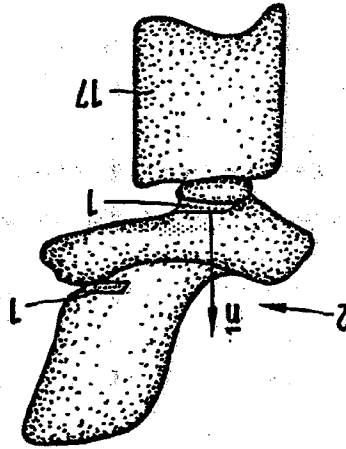
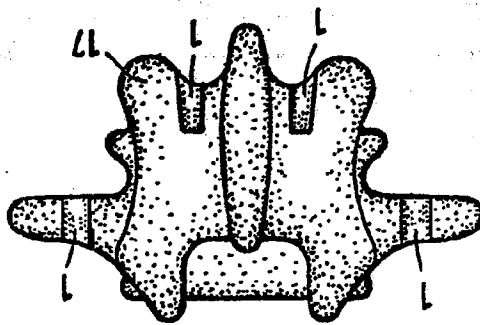

FIG. 2a



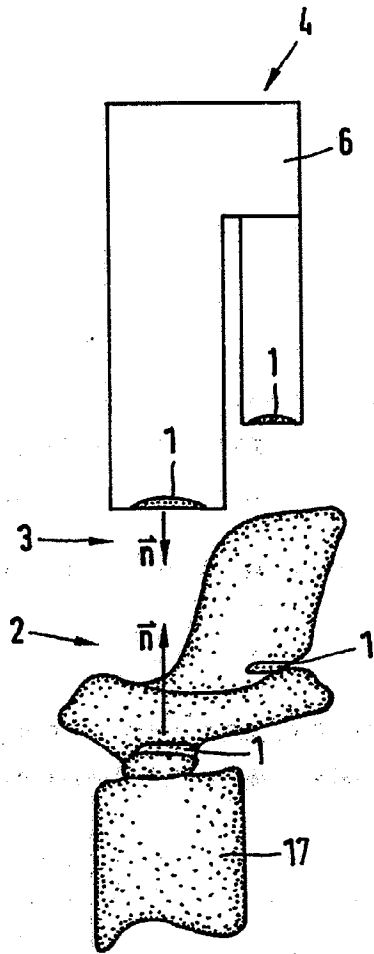

FIG. 3a

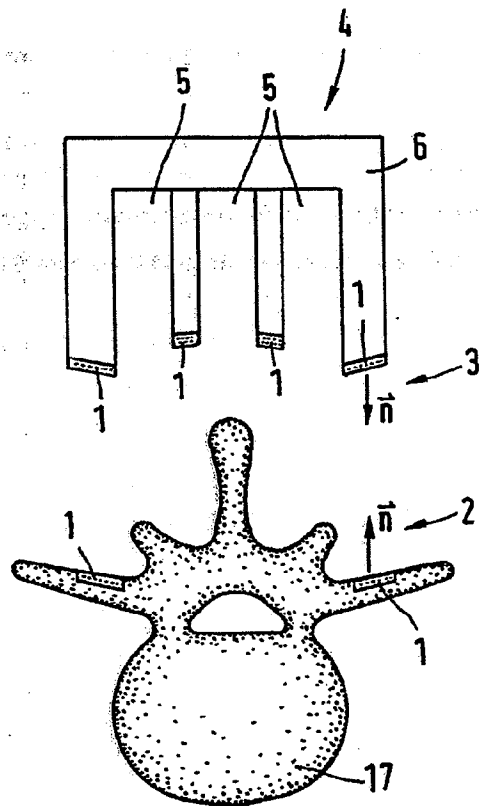

FIG. 3b

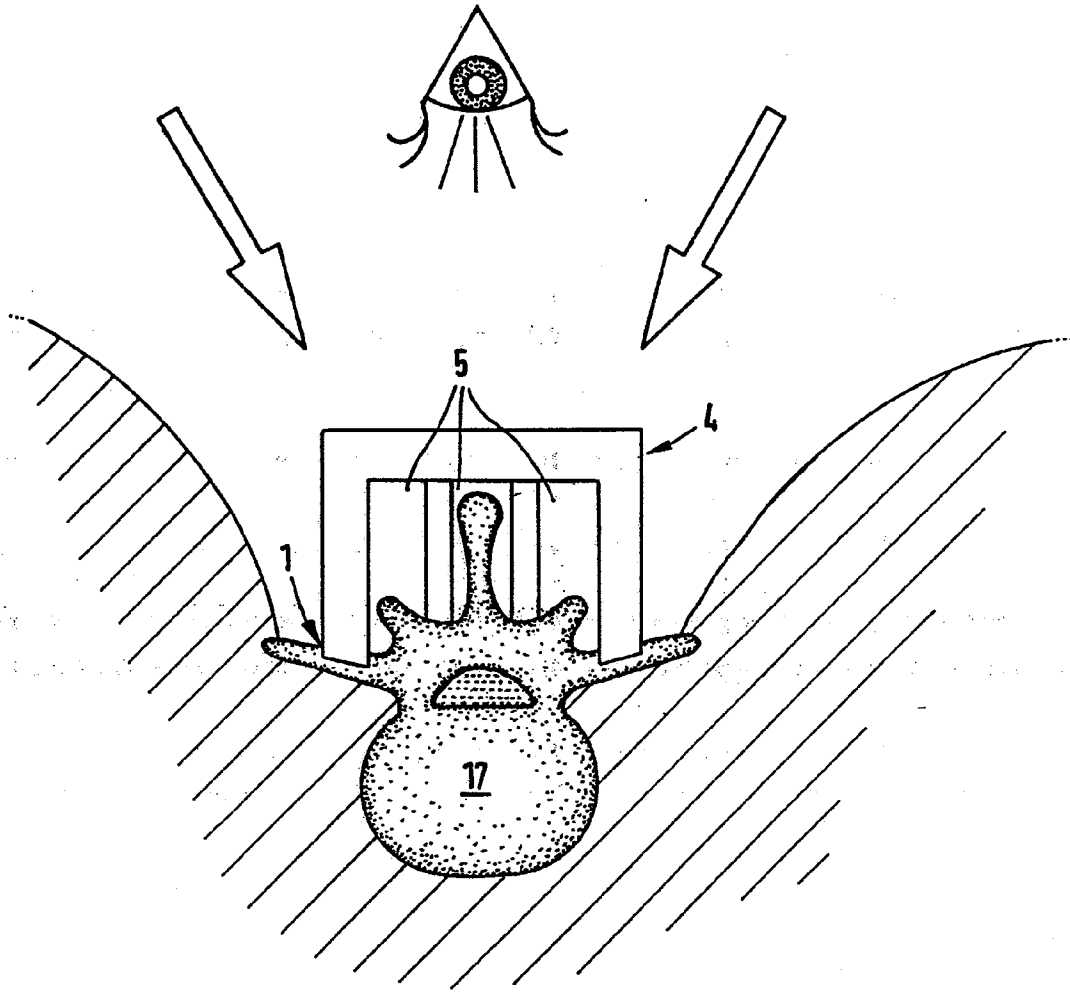

FIG. 4

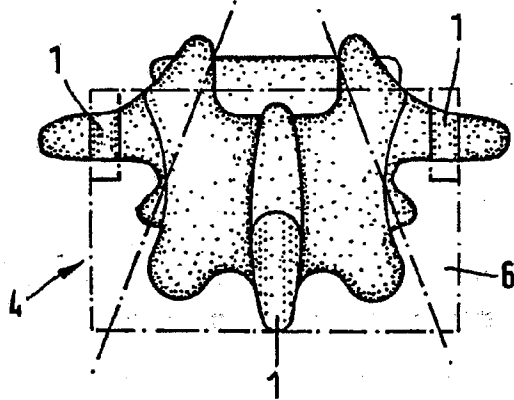

FIG. 5a

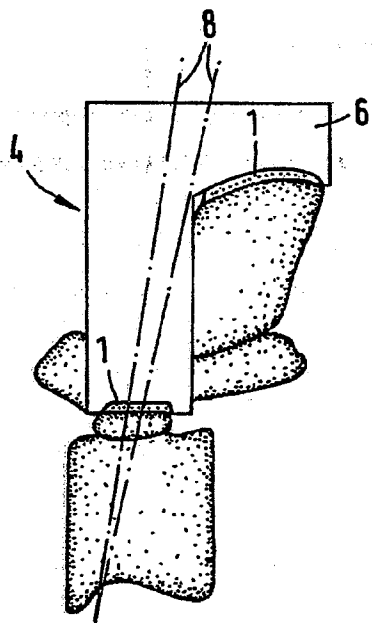

FIG. 5b

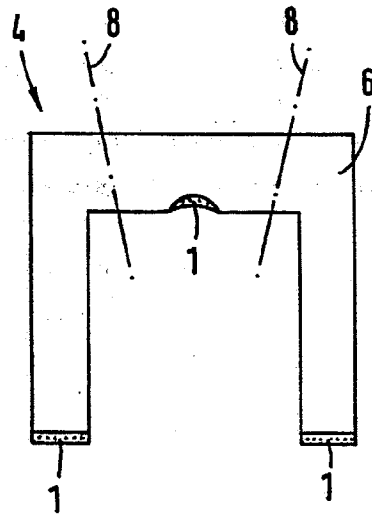
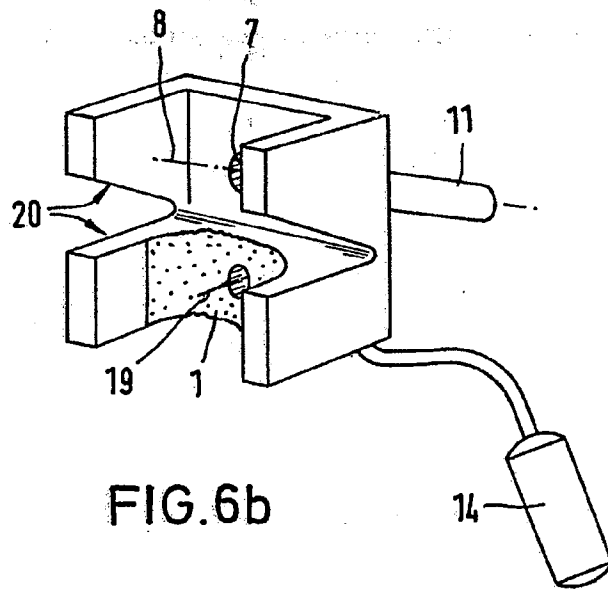
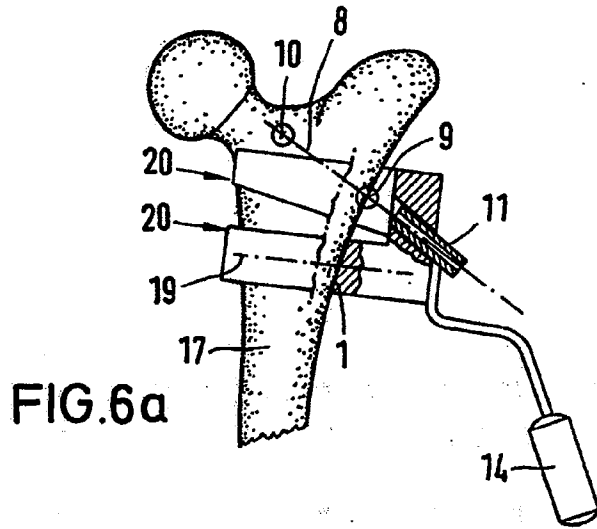

FIG. 5c



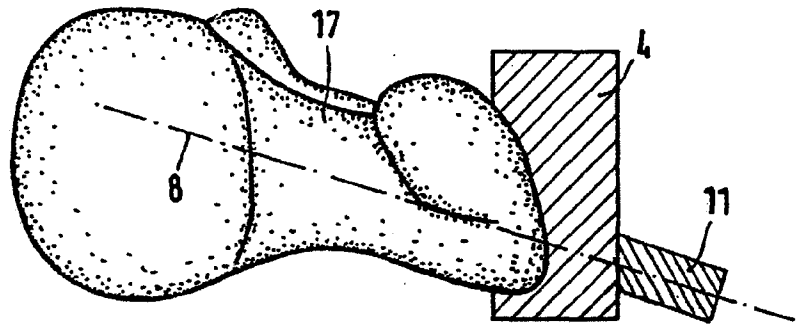

FIG. 7b

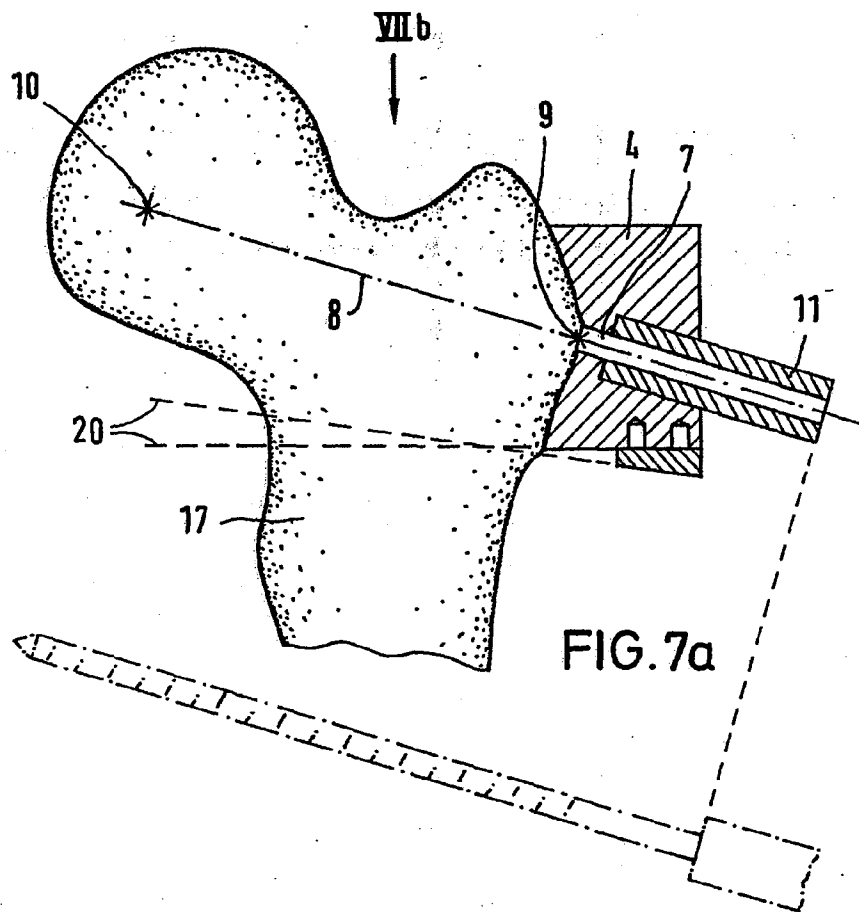
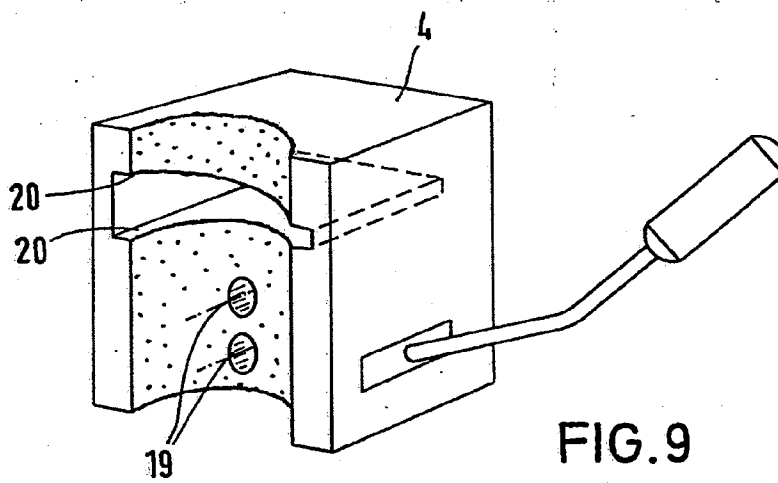
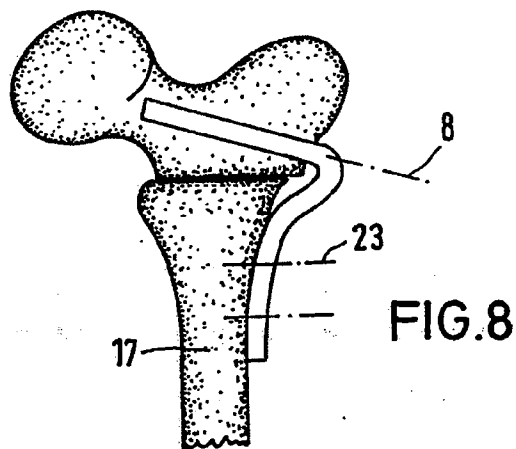
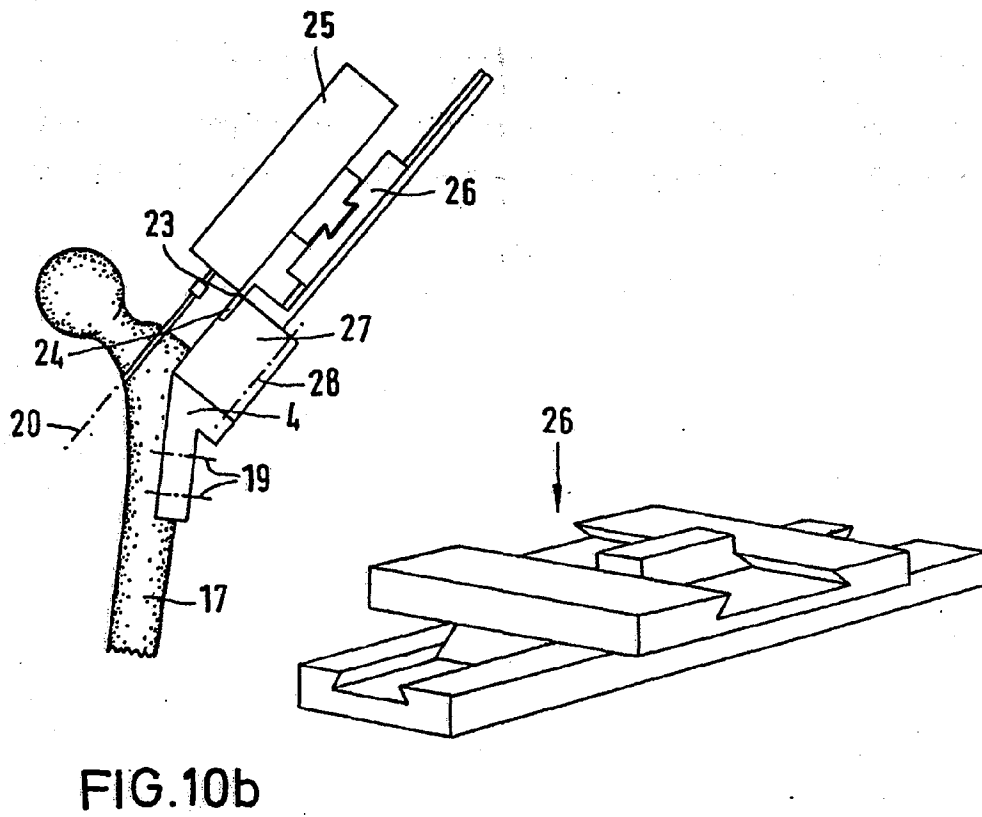
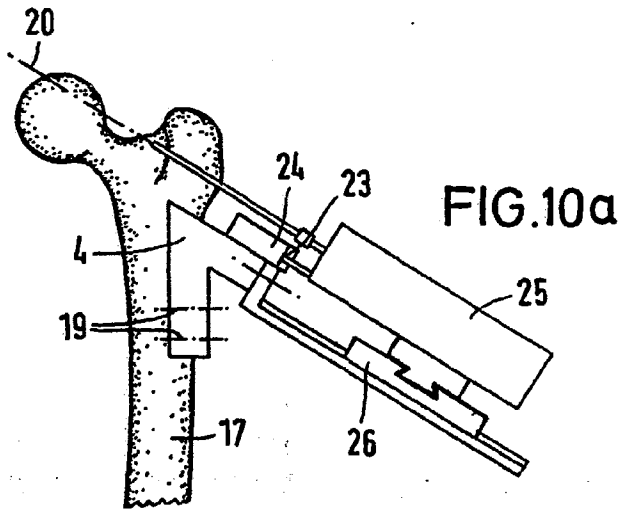

FIG. 7a





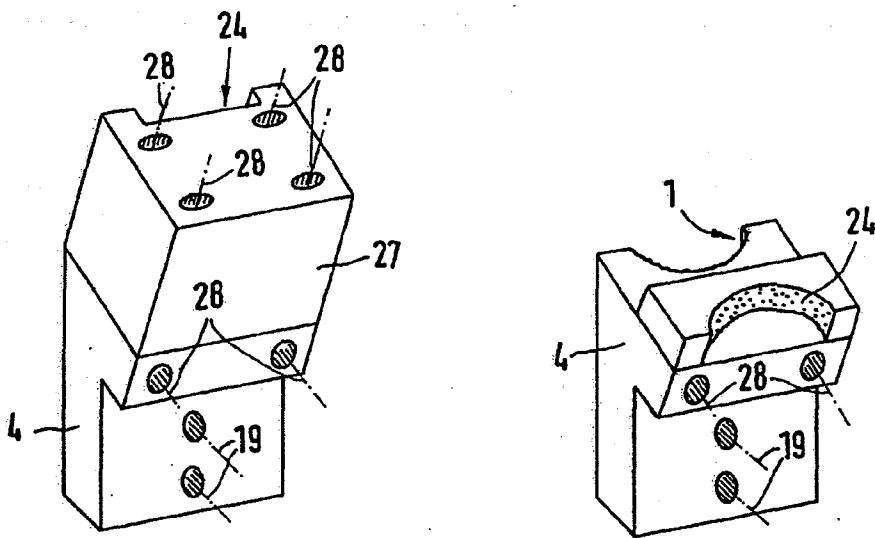
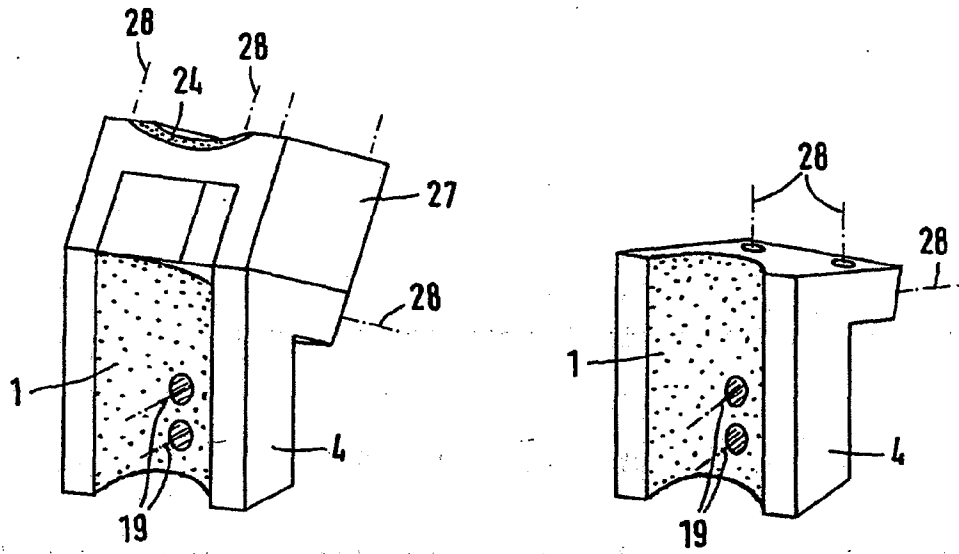

FIG. 10c

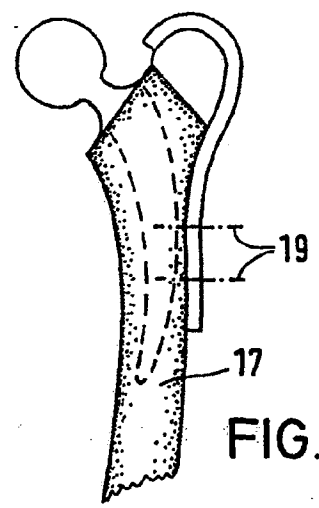

FIG. 10d

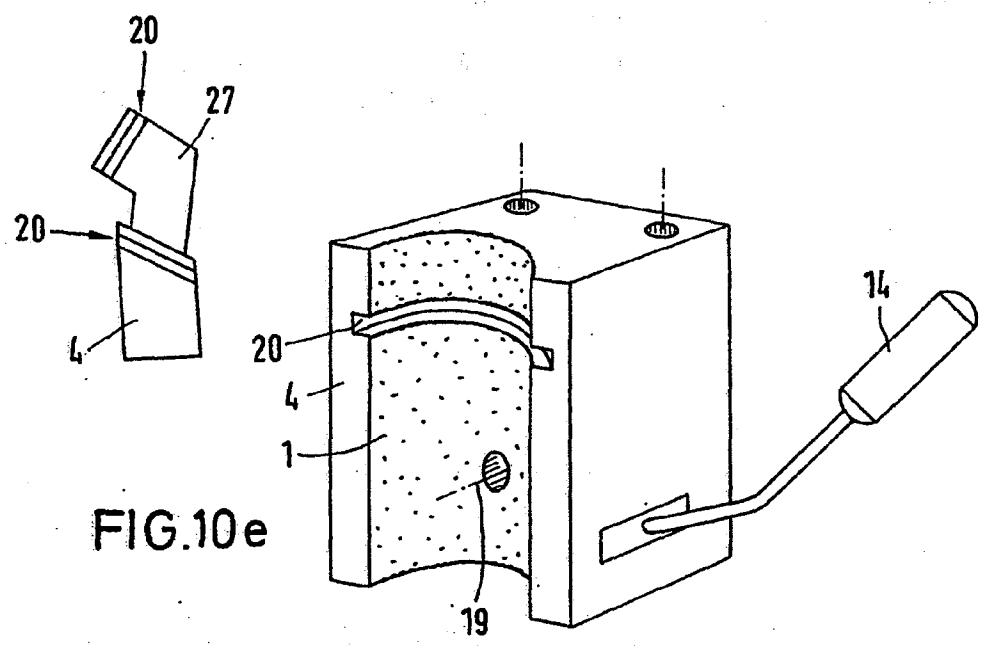
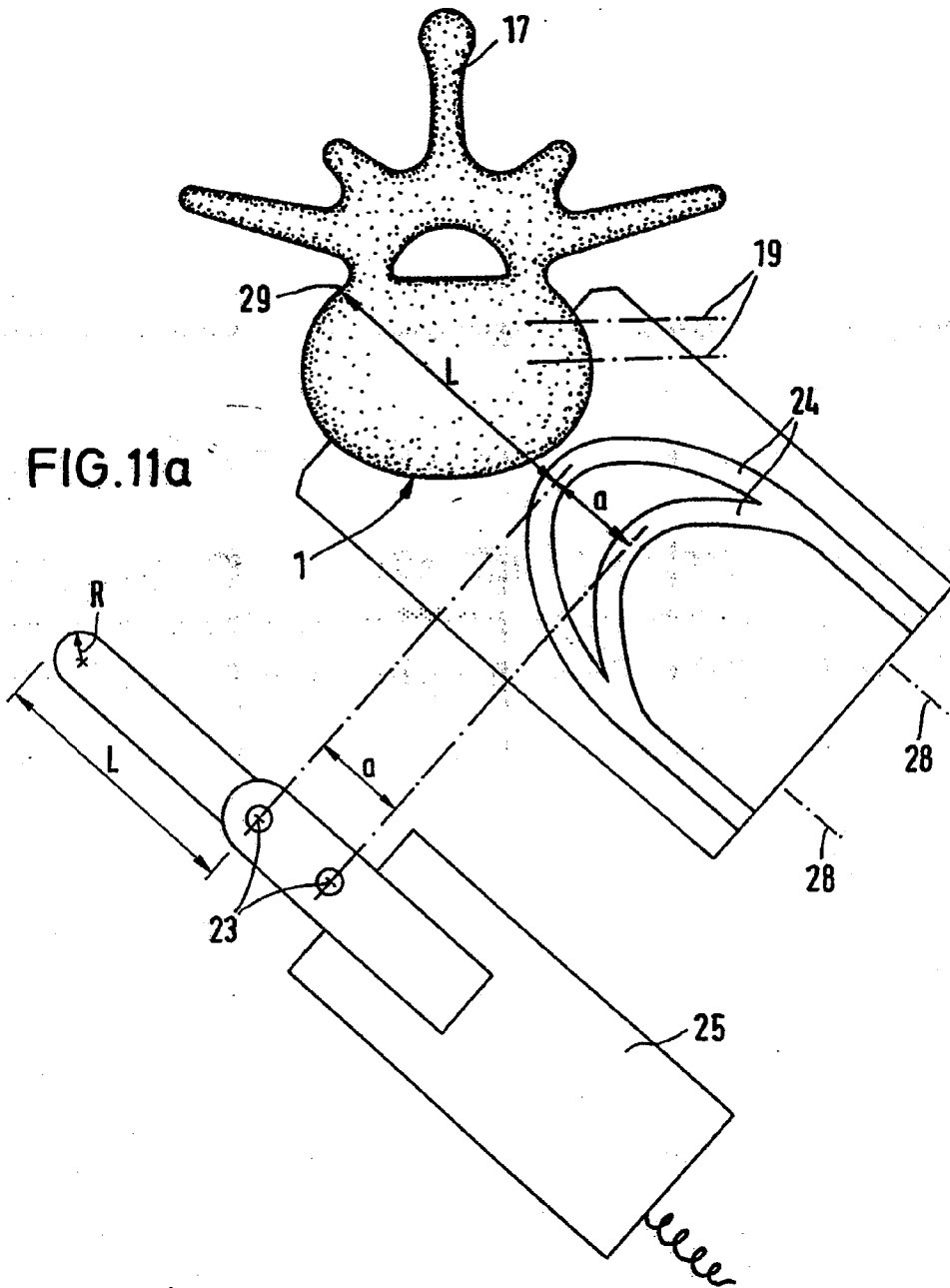

FIG. 10e



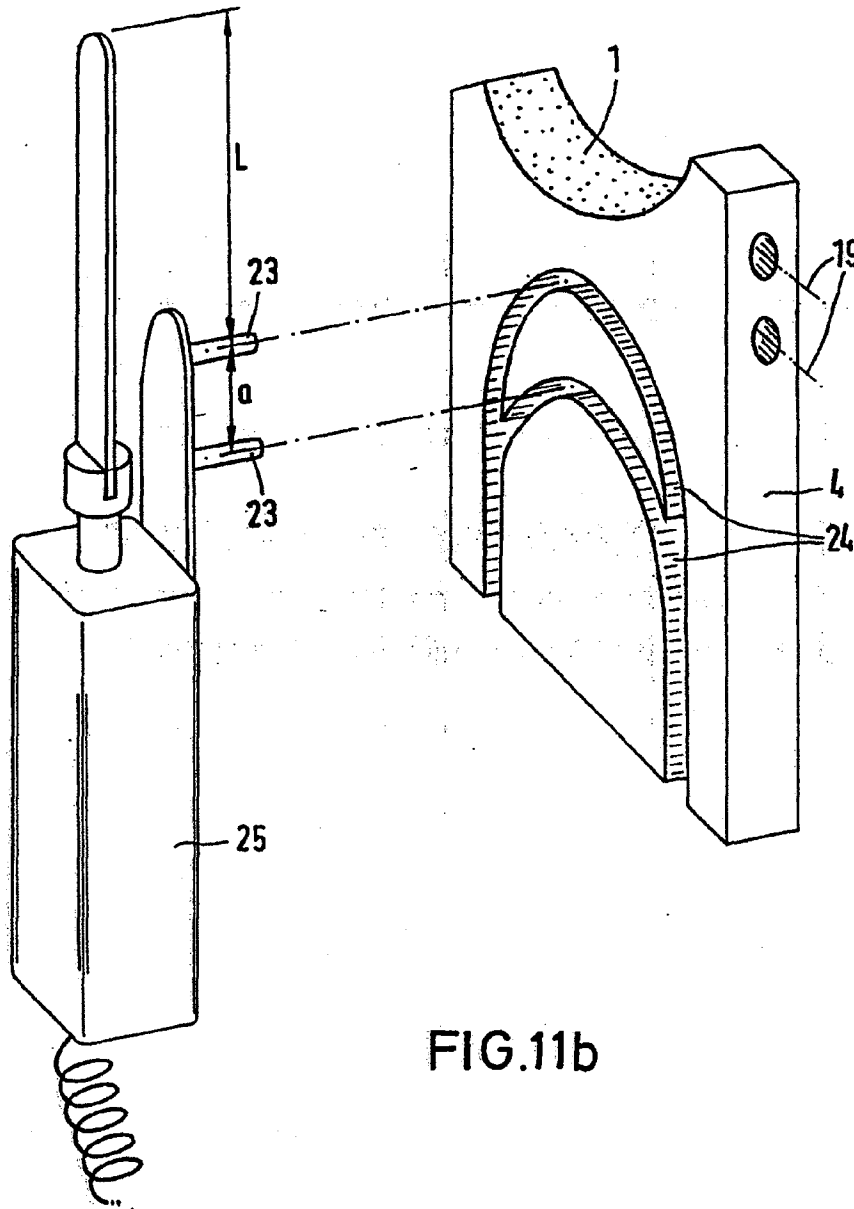

FIG.11b

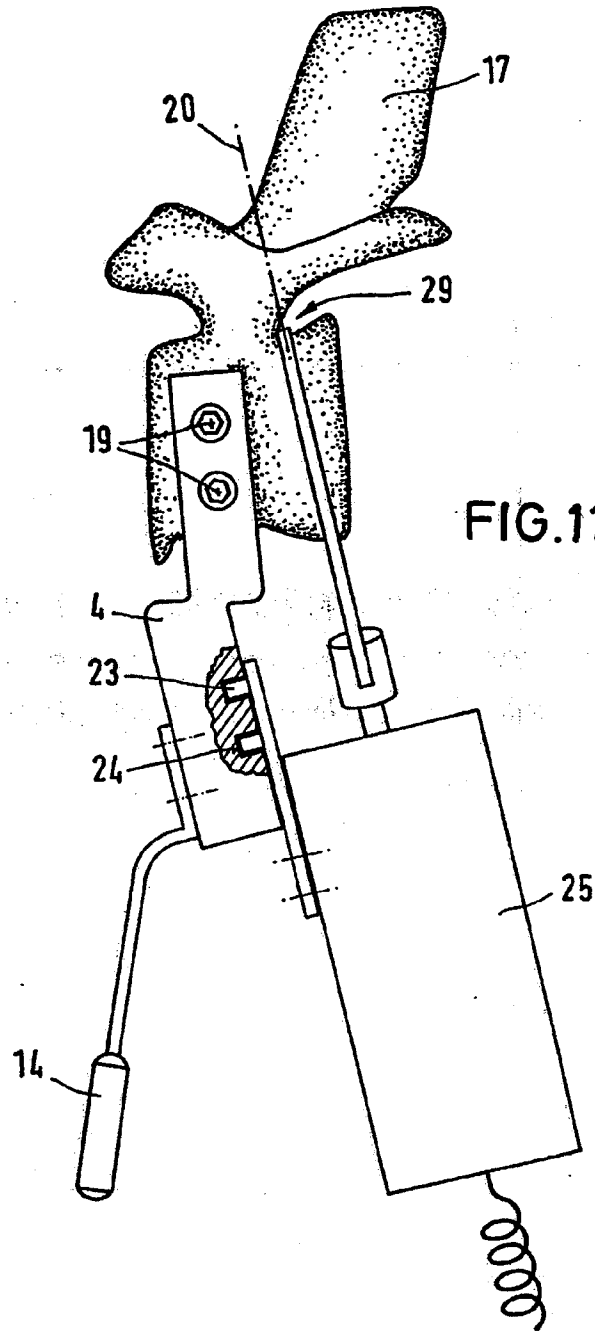

FIG.11c

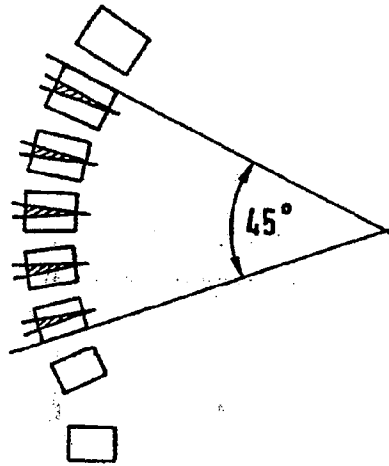

FIG.11d



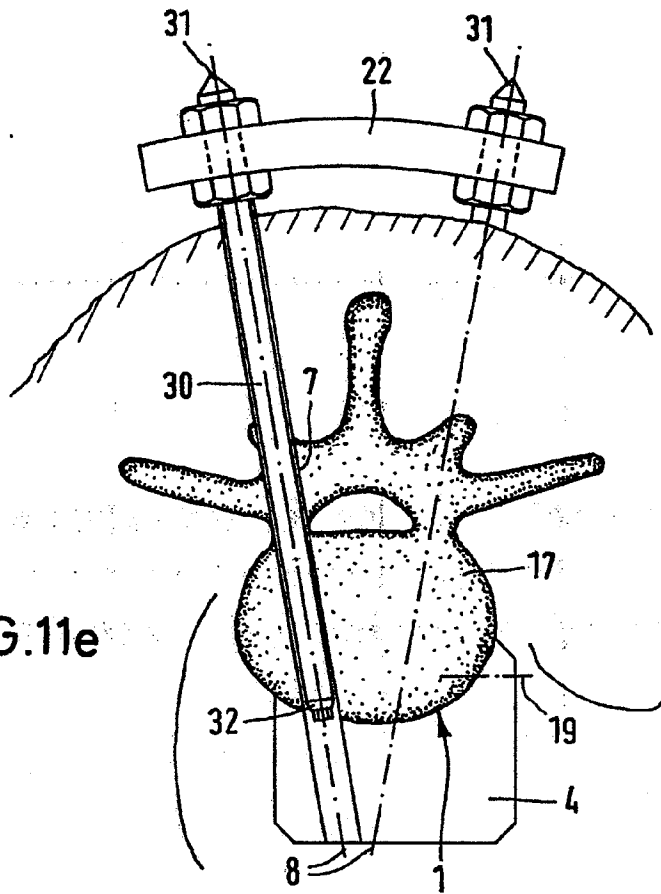

FIG.11e

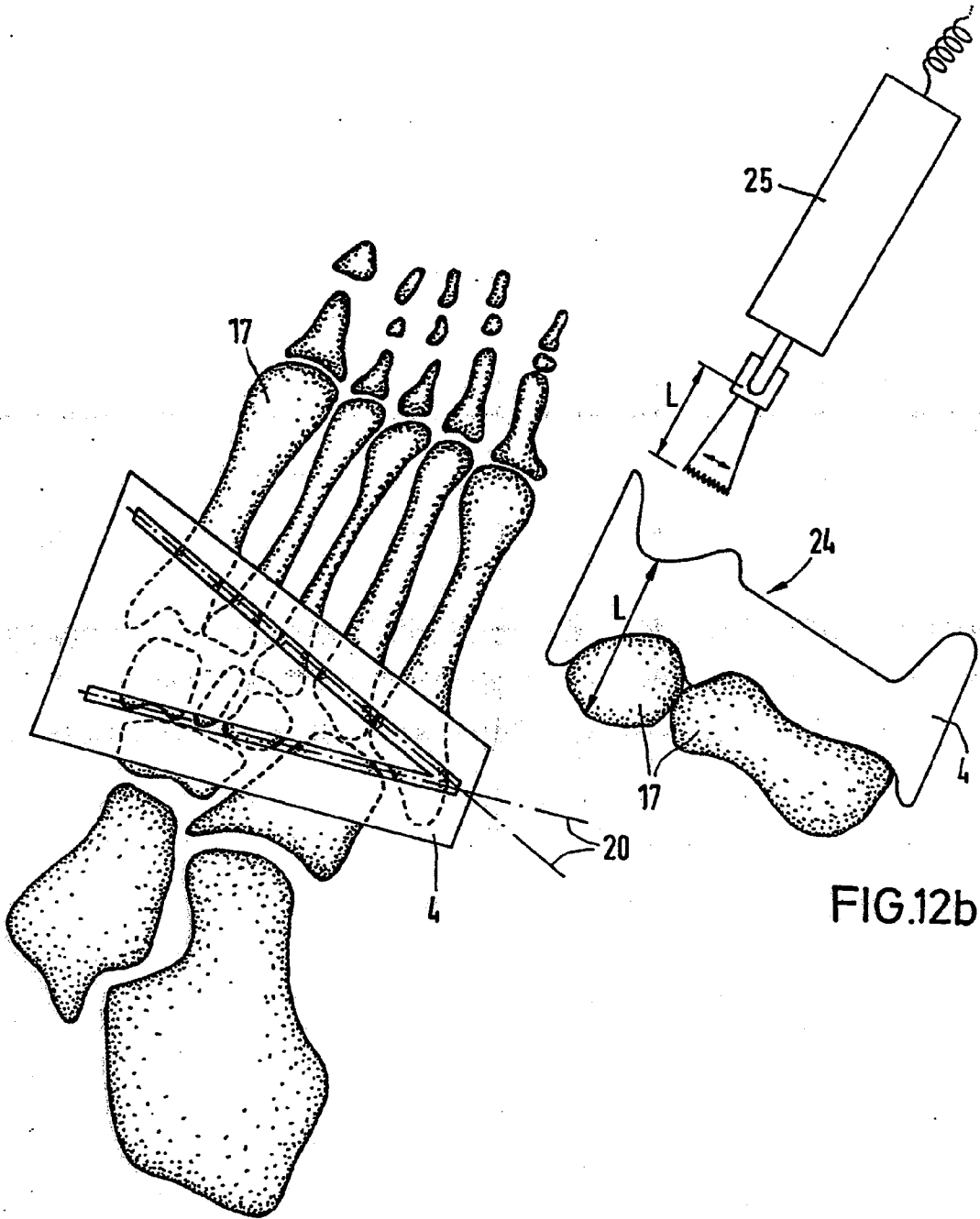
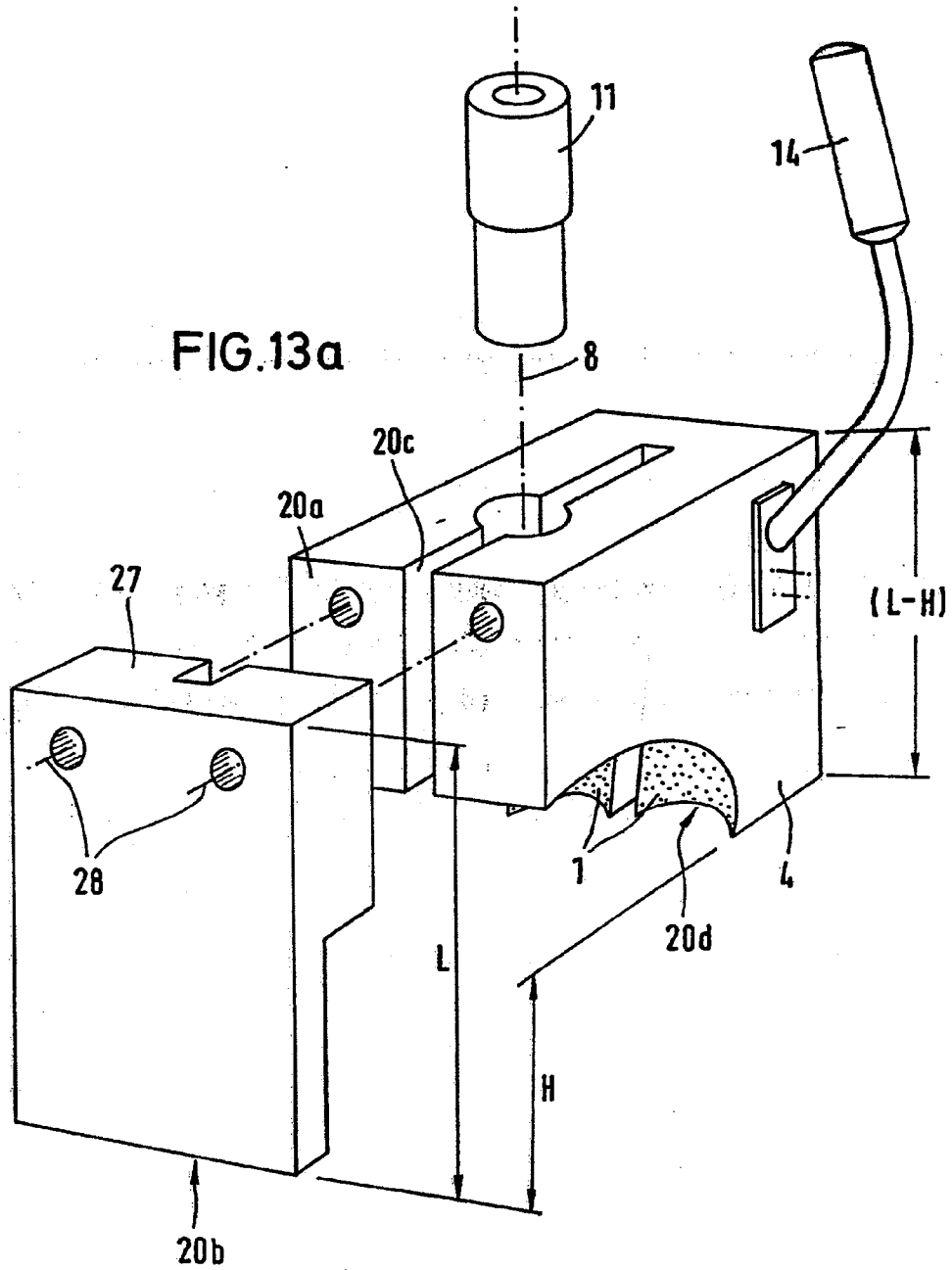

FIG.12a

FIG.12b



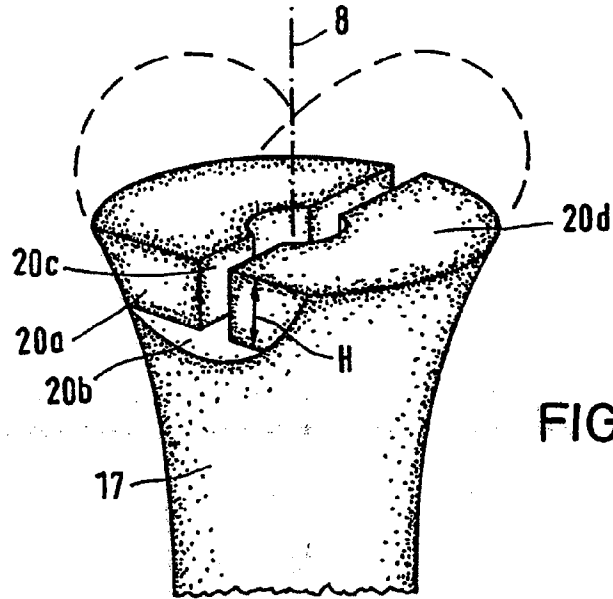

FIG. 13b

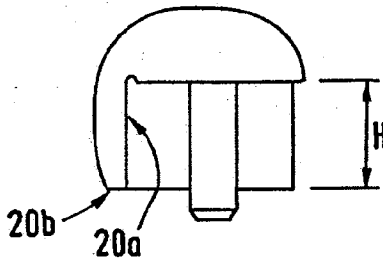
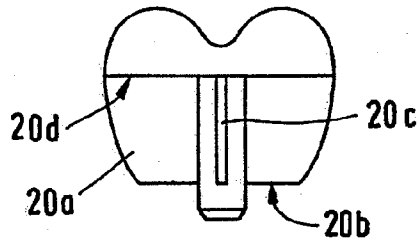

FIG. 13d



-20/29-

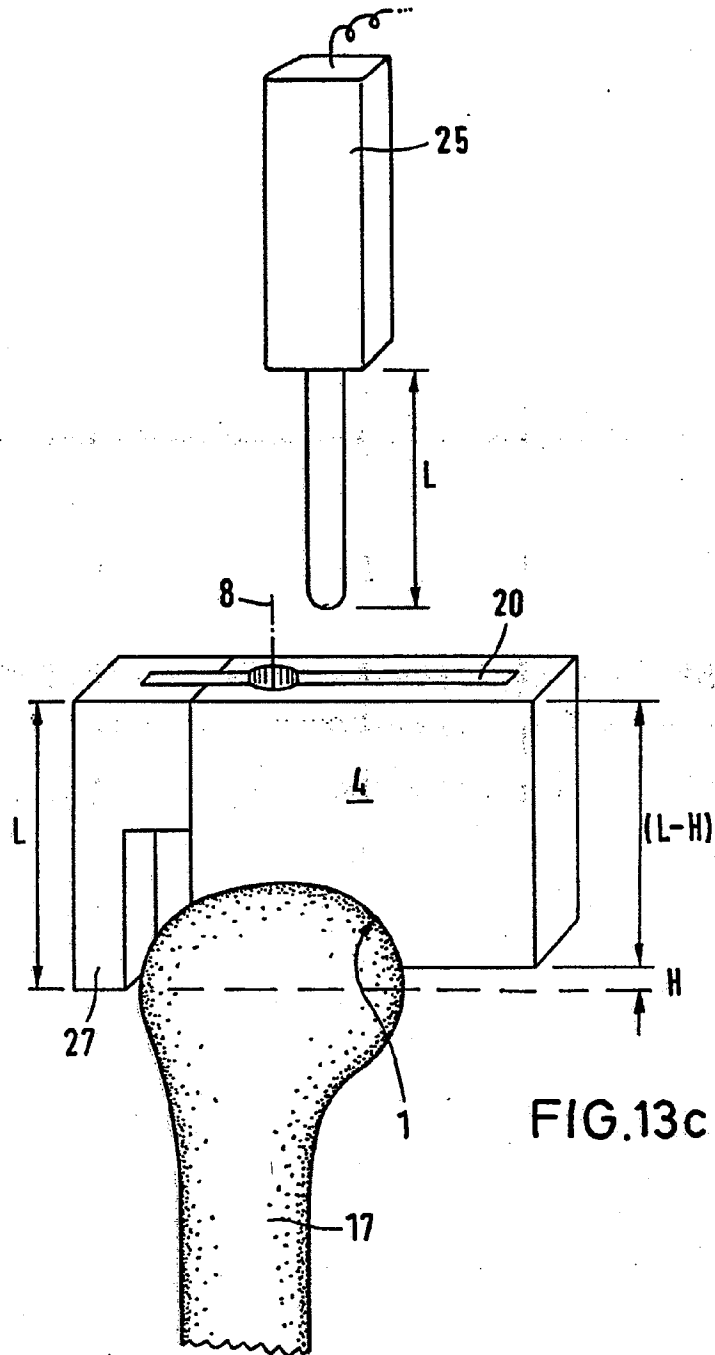

FIG.13c

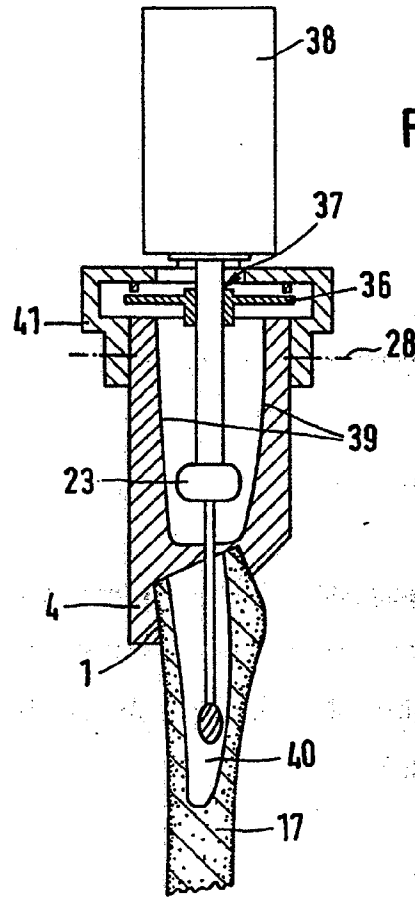

FIG.14a

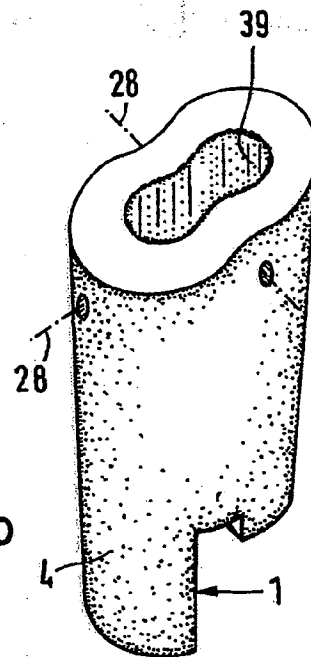

FIG.14b

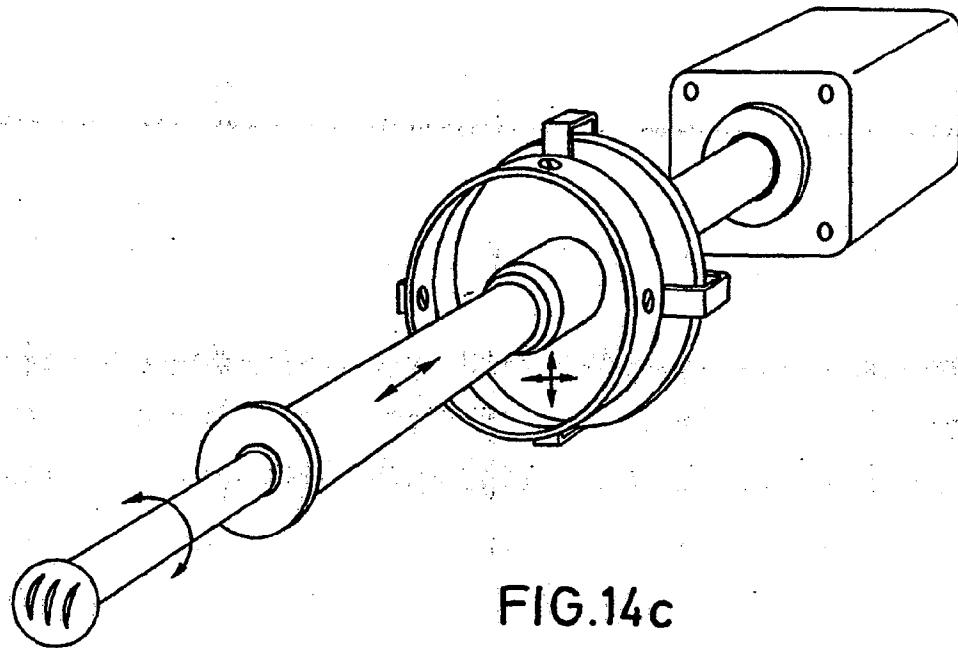
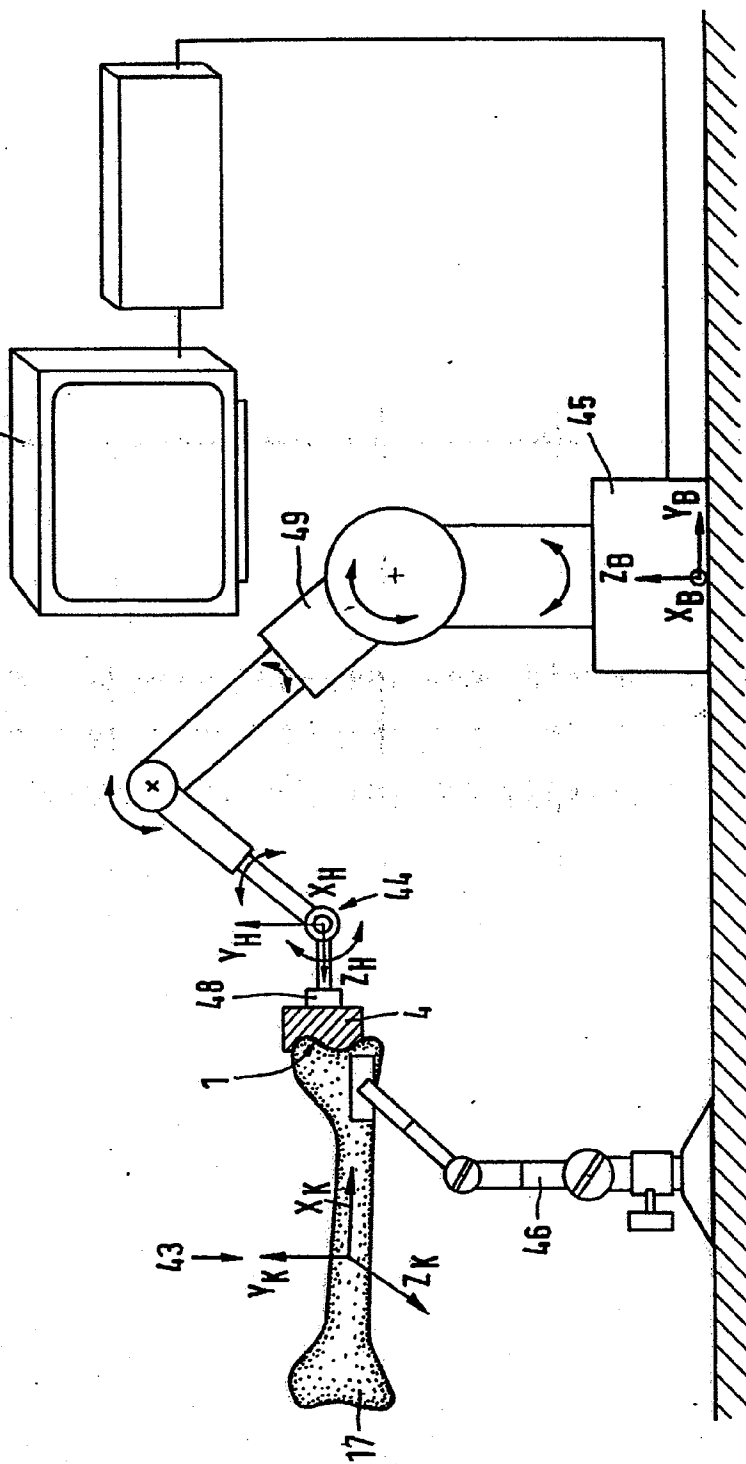

FIG.14c

FIG. 15a



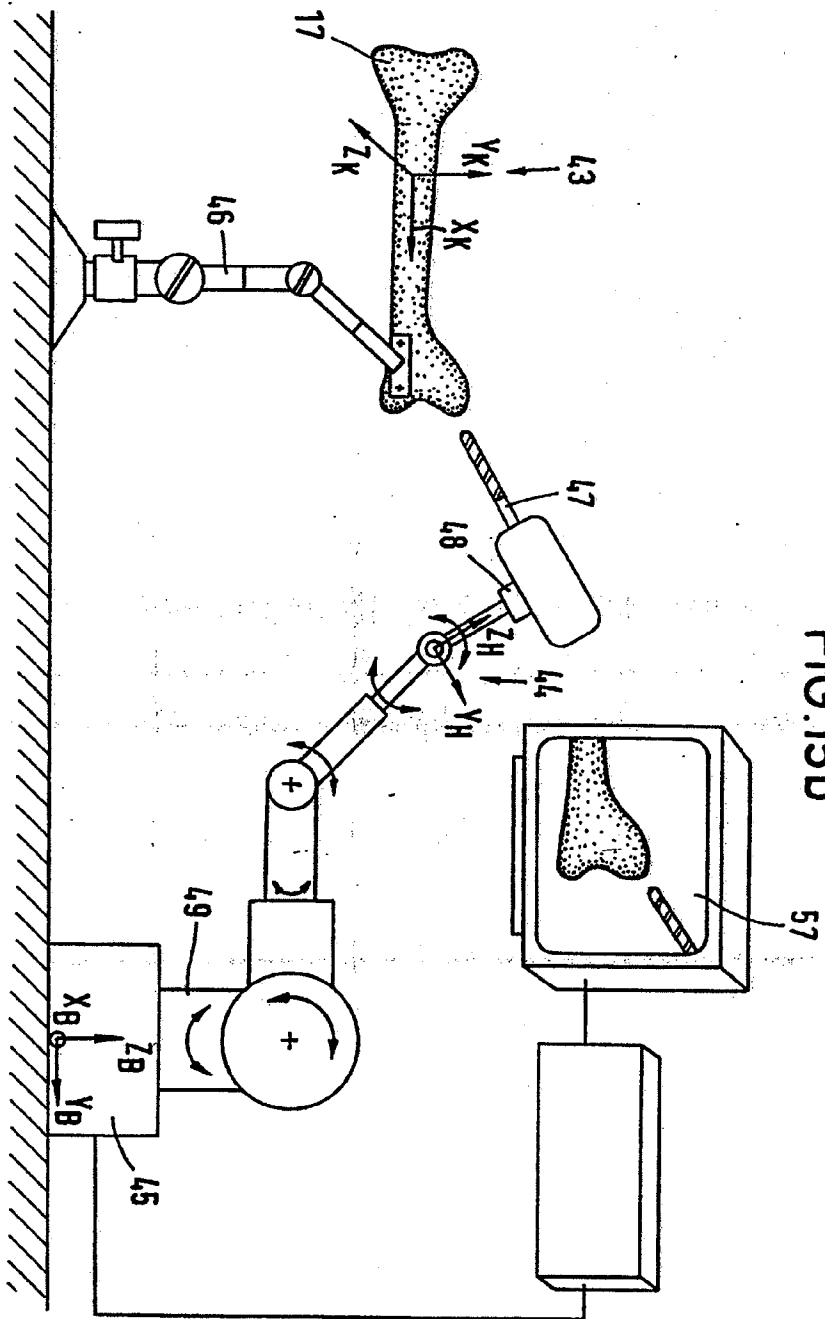

FIG. 15B

-25/29-

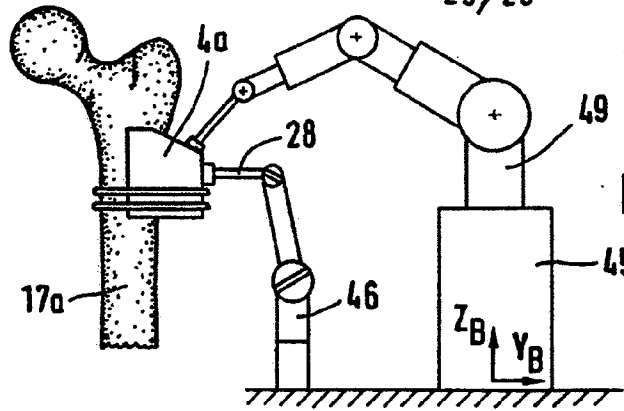

FIG. 16a

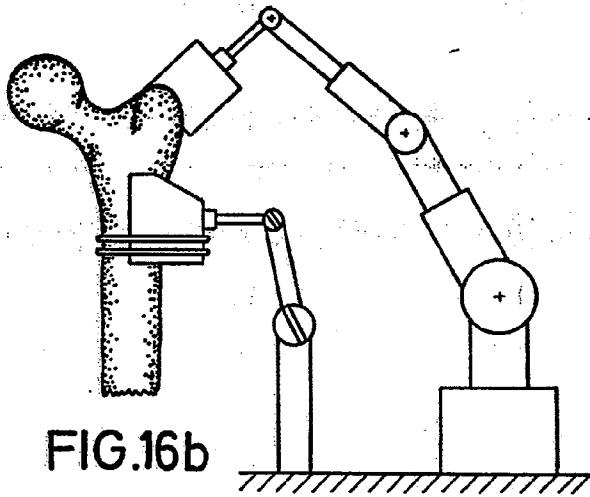
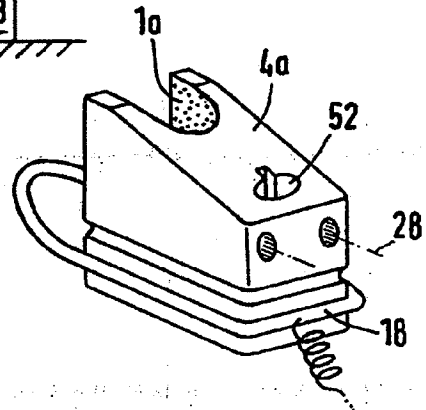

FIG. 16b

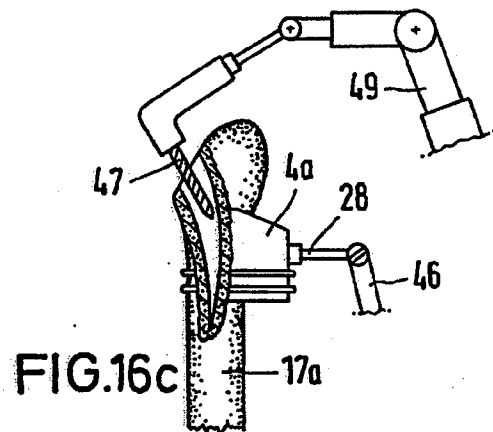

FIG. 16c

FIG.16d

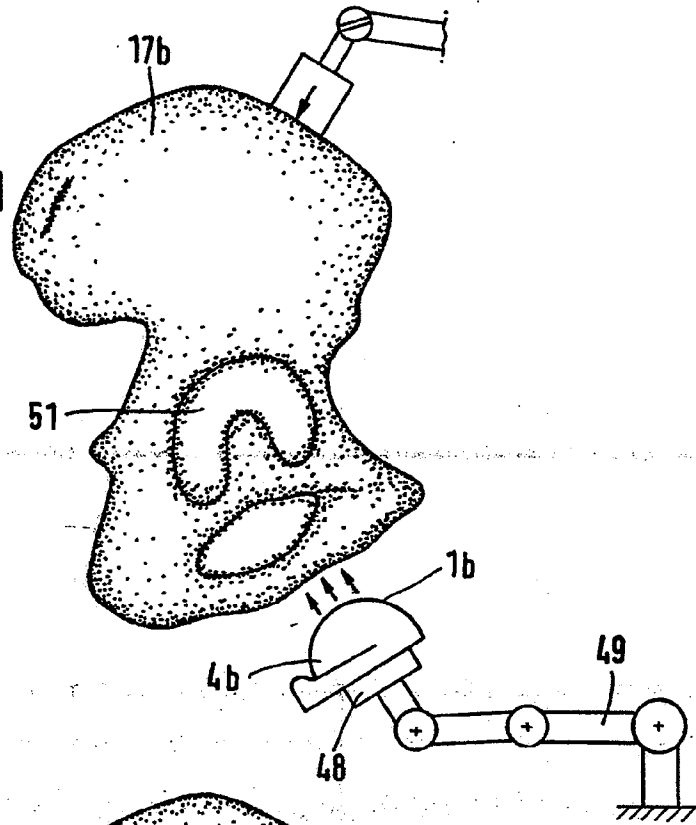
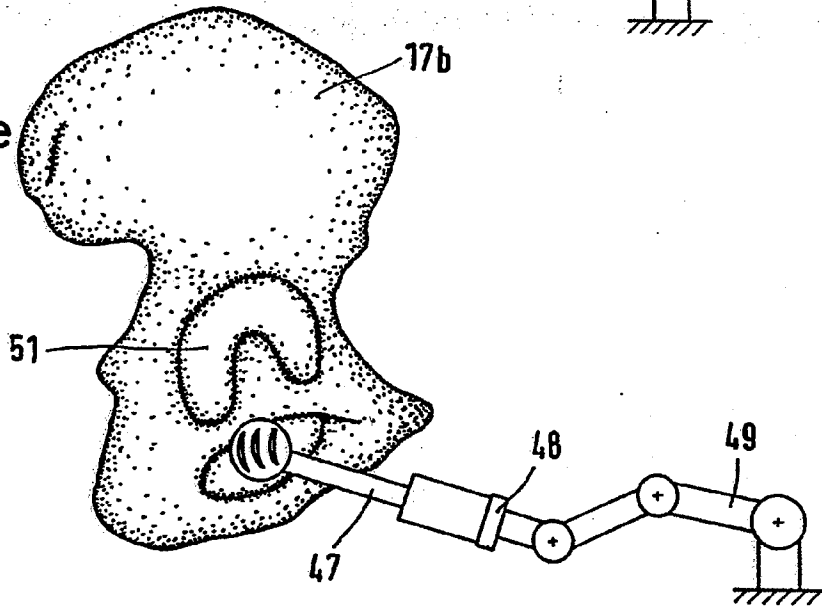

FIG.16e



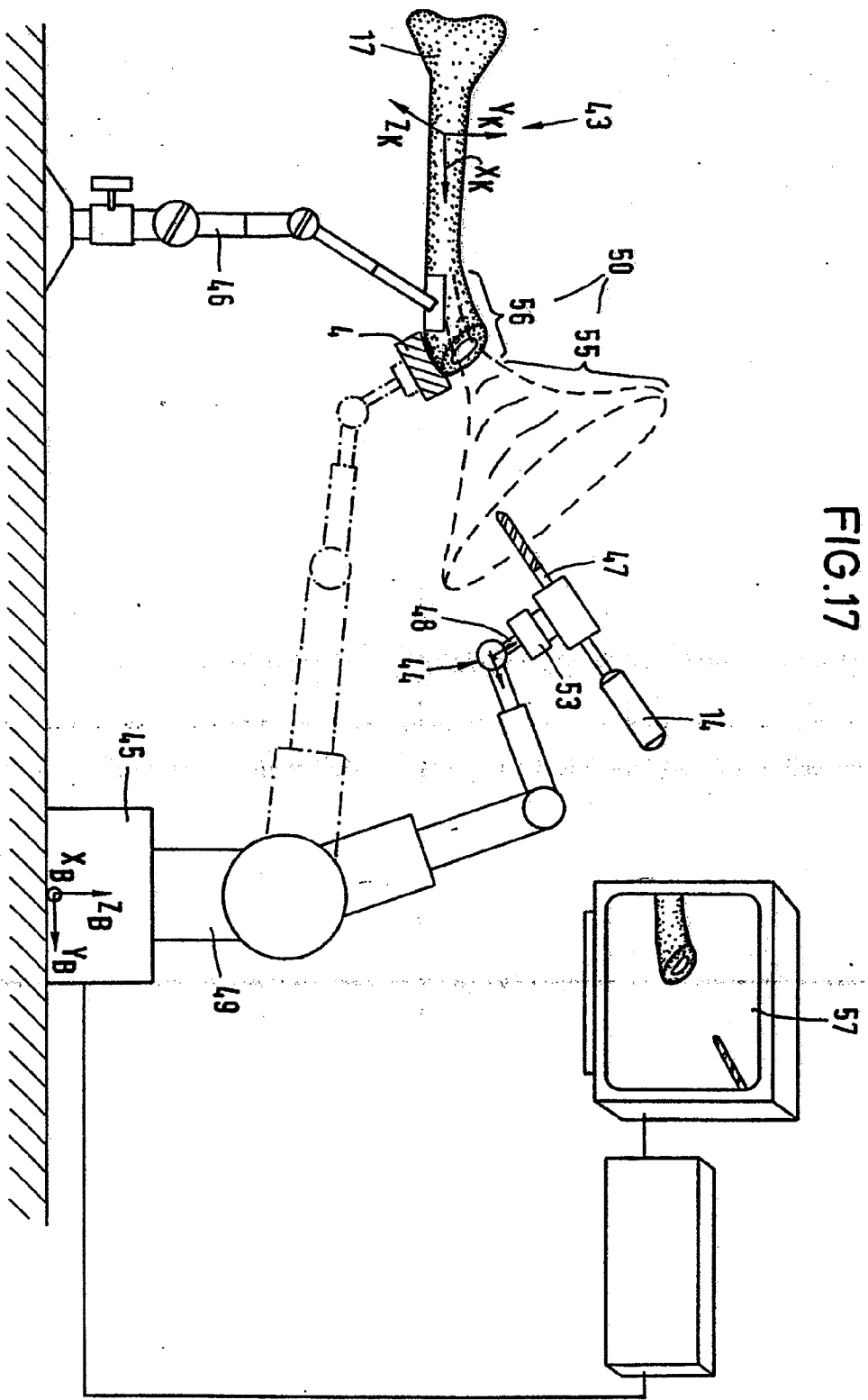

FIG. 17

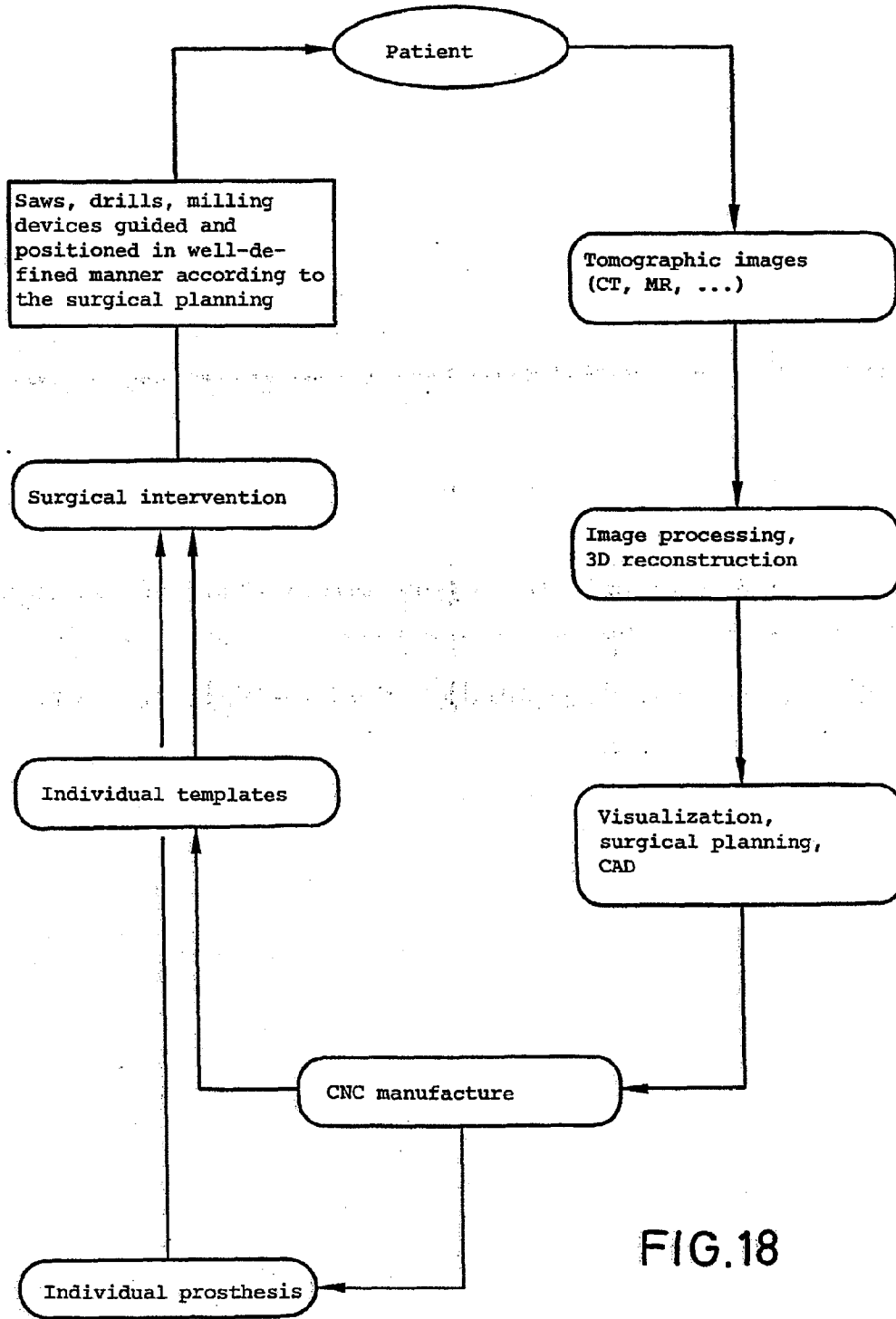

FIG.18

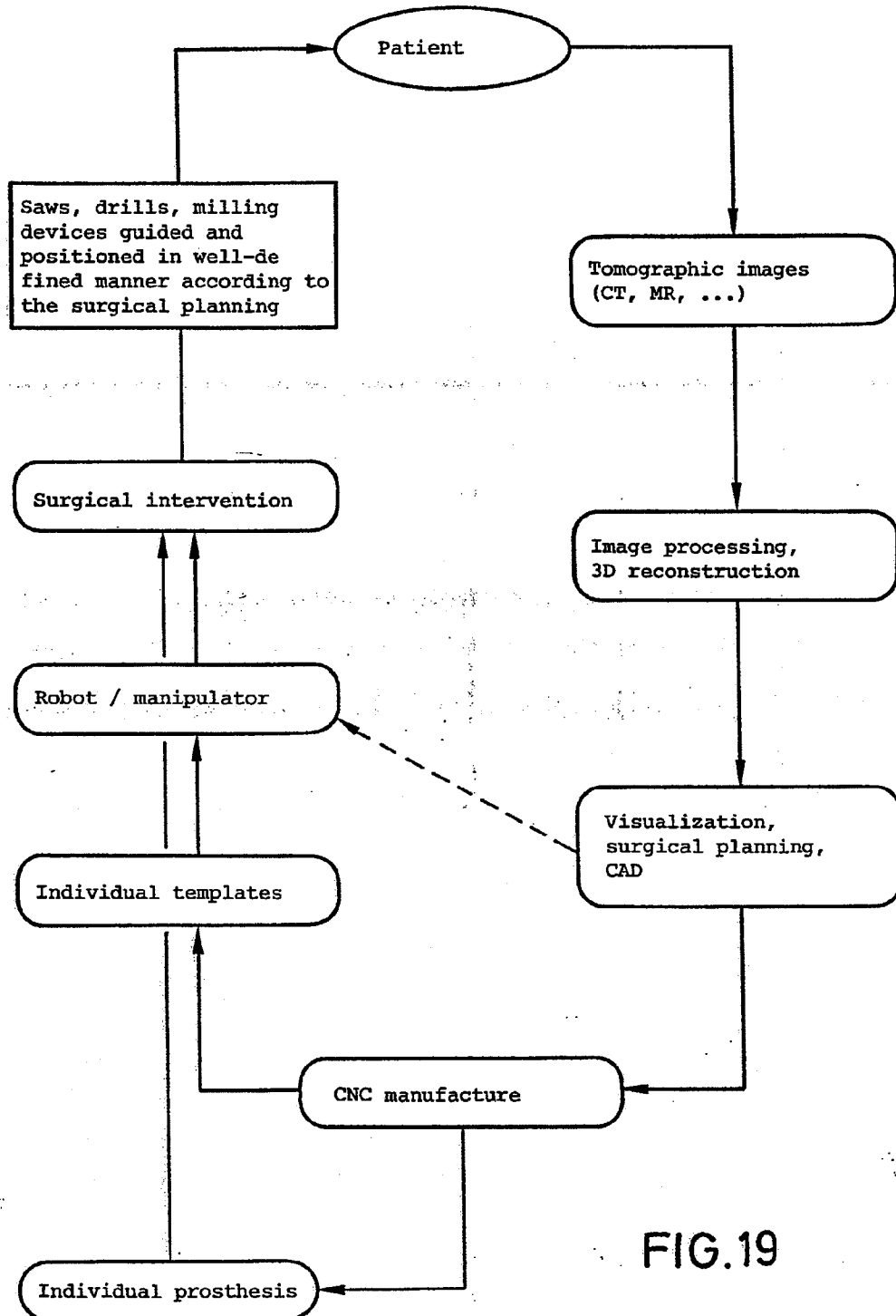

FIG.19

INTERNATIONAL SEARCH REPORT

International Application No

PCT/EP 93/01540

I. CLASSIFICATION OF SUBJECT MATTER (if several classification symbols apply, indicate all) *		
According to International Patent Classification (IPC) or to both National Classification and IPC		
IPC ⁵ : A 61 B 17/56		
II. FIELDS SEARCHED		
Minimum Documentation Searched ⁷		
Classification System	Classification Symbols	
IPC ⁵	A 61 B	
Documentation Searched other than Minimum Documentation to the Extent that such Documents are Included in the Fields Searched ⁸		
III. DOCUMENTS CONSIDERED TO BE RELEVANT⁹		
Category ¹⁰	Citation of Document, ¹¹ with indication, where appropriate, of the relevant passages ¹²	Relevant to Claim No. ¹³
Y	US, A, 4 979 949 (F.A. MATSEN et al.) 25 December 1990 (25.12.90), the whole document; especially fig. 3, 15-18; column 5, lines 14-68; column 8, lines 9-35; column 9, line 29 - column 10, line 60; column 17, line 52 - column 18, line 4; column 21, line 3 - column 23, line 35; column 28, line 50 - column 29, line 9.	1, 2, 5-8
X	---	3, 4
Y	GB, A, 4 846 161 (G.J. ROGER) 11 July 1989 (11.07.89), abstract; column 3, lines 5-22 (cited in the application).	1, 2, 5-8
<p>* Special categories of cited documents: ¹⁴</p> <p>"A" document defining the general state of the art which is not considered to be of particular relevance</p> <p>"E" earlier document but published on or after the international filing date</p> <p>"L" document which may throw doubts on priority claim(s) or which is cited to establish the publication date of another citation or other special reason (as specified)</p> <p>"O" document referring to an oral disclosure, use, exhibition or other means</p> <p>"P" document published prior to the international filing date but later than the priority date claimed</p> <p>"T" later document published after the international filing date or priority date and not in conflict with the application but cited to understand the principle or theory underlying the invention</p> <p>"X" document of particular relevance; the claimed invention cannot be considered novel or cannot be considered to involve an inventive step</p> <p>"Y" document of particular relevance; the claimed invention cannot be considered to involve an inventive step when the document is combined with one or more other such documents, such combination being obvious to a person skilled in the art.</p> <p>"Z" document member of the same patent family</p>		
IV. CERTIFICATION		
Date of the Actual Completion of the International Search	Date of Mailing of this International Search Report	
30 September 1993	15. 10. 93	
International Searching Authority	Signature of Authorized Officer	
EUROPEAN PATENT OFFICE	LUDWIG e.h.	

III. DOCUMENTS CONSIDERED TO BE RELEVANT (CONTINUED FROM THE SECOND SHEET)		
Category *	Citation of Document, ** with indication, where appropriate, of the relevant passages	Relevant to Claim No.
Y	US, A, 4 841 975 (S.T. WOOLSON) 27 June 1989 (27.06.89), the whole document; especially abstract; column 2, lines 28-59. -----	1, 2, 5-8

ANHANG

zum internationalen Recherchenbericht über die internationale Patentanmeldung Nr.

ANNEX

to the International Search Report to the International Patent Application No.

ANNEXE

au rapport de recherche international relatif à la demande de brevet international n°

PCT/EP 93/01540 SAE 75914

In diesem Anhang sind die Mitglieder der Patentfamilien der in obengenannten internationalen Recherchenbericht angeführten Patentedokumente angegeben. Diese Angaben dienen nur zur Unterrichtung und erfolgen ohne Gewähr.

This Annex lists the patent family members relating to the patent documents cited in the above-mentioned international search report. The Office is in no way liable for these particulars which are given merely for the purpose of information.

La présente annexe indique les membres de la famille de brevets relatifs aux documents de brevets cités dans le rapport de recherche international visée ci-dessus. Les renseignements fournis sont donnés à titre indicatif et n'engagent pas la responsabilité de l'Office.

In Recherchenbericht angeführtes Patentedokument Patent document cited in search report Document de brevet cité dans le rapport de recherche	Datum der Veröffentlichung Publication date Date de publication	Mitglied(er) der Patentfamilie Patent family member(s) Membre(s) de la famille de brevets	Datum der Veröffentlichung Publication date Date de publication
US A 4979949	25-12-90	US A 5154717 US A 5236432	13-10-92 17-08-93
US A 4846161	11-07-89	AU A1 65500/86 AU B2 590807 EP A1 243410 WO A1 8702571	19-05-87 16-11-89 04-11-87 07-05-87
US A 4841975	27-06-89	WO A1 8807840	20-10-88